

# Whirlpool®

## Model WHADUS5

How to install, operate  
and maintain your  
Dual Stage  
Water Filtration System

### PRODUCT REGISTRATION AND WARRANTY EXTENSION

Please register your product on  
[whirlpoolwatersolutions.com](http://whirlpoolwatersolutions.com)

See warranty page for  
extended warranty details.

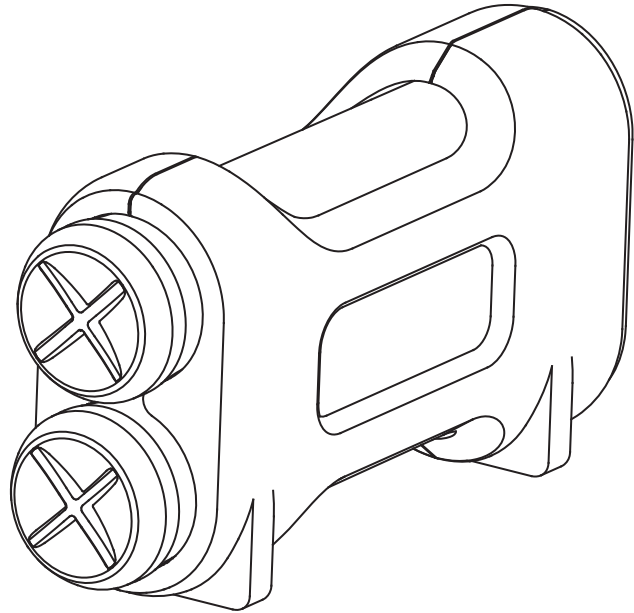

# Installation and Operation Manual

If you have any questions or concerns when  
installing, operating or maintaining your water  
filtration system, call our toll free number:

**1-866-986-3223**

or visit **[whirlpoolwatersolutions.com](http://whirlpoolwatersolutions.com)**

When you call, please be prepared to provide  
the model number and date code of your  
product, found on the rating decal on back.

System tested and certified by NSF International  
against NSF/ANSI Standard 42 for the reduction  
of chlorine taste and odor, and Standard 53 for  
the reduction of cysts, lead, MTBE and VOCs.



Manufactured and warranted by  
Water Channel Partners  
1890 Woodlane Drive  
Woodbury, MN 55125

7387356 (Rev. C 2/29/24)

## TABLE OF CONTENTS

	Page
Specifications & Performance Claims .....	3-4
Before You Start / Dimensions .....	5
Parts of the System / Materials & Tools Needed .....	6
Installation Instructions .....	7-9
Filter Cartridge Life & Replacement .....	10
Troubleshooting the System .....	11
Parts List .....	12
Warranty .....	13

## COIN BATTERY INFORMATION

- Battery type: CR2032. Nominal voltage: 3.0 V.
- Ensure the battery is installed correctly according to polarity (+ and -).
- Non-rechargeable batteries are not to be recharged.
- Remove and immediately recycle or dispose of used batteries according to local regulations and keep away from children. Do NOT dispose of batteries in household trash or incinerate.
- Even used batteries may cause severe injury or death.
- Call a local poison control center for treatment information.
- Do not force discharge, recharge, disassemble, heat above 140°F (60°C) or incinerate. Doing so may result in injury due to venting, leakage or explosion resulting in chemical burns.
- In products using more than one battery, do not mix old and new batteries, different brands or types of batteries, such as alkaline, carbon-zinc, or rechargeable batteries.
- Remove and immediately recycle or dispose of batteries from equipment not used for an extended period of time according to local regulations.
- Always completely secure the battery compartment. If the battery compartment does not close securely, stop using the product, remove the battery, and keep it away from children.

<b>⚠ WARNING</b>	
<ul style="list-style-type: none"><li>• <b>INGESTION HAZARD:</b> This product contains a button cell or coin battery.</li><li>• <b>DEATH</b> or serious injury can occur if ingested.</li><li>• A swallowed button cell or coin battery can cause <b>Internal Chemical Burns</b> in as little as <b>2 hours</b>.</li><li>• <b>KEEP</b> new and used batteries <b>OUT OF REACH of CHILDREN</b>.</li><li>• <b>Seek immediate medical attention</b> if a battery is suspected to be swallowed or inserted inside any part of the body.</li></ul>	

- This system has a lithium battery containing perchlorate. Per California Regulation: Perchlorate Material – Special handling may apply. See [www.dtsc.ca.gov/hazardouswaste/perchlorate](http://www.dtsc.ca.gov/hazardouswaste/perchlorate).

# Specifications & Performance Claims

SPECIFICATIONS	
Supply Water Pressure Min. - Max.	30 - 100 psi (207 - 689 kPa)
Supply Water Temperature Min. - Max.	40 - 100 °F (4 - 38 °C)
Rated Service Flow	0.5 gallons per minute (1.89 liters per minute)
Filter Service Life	270 gallons (1,022 liters)
Inlet - Outlet	3/8" quick connect fittings

This system conforms to NSF/ANSI 42 and 53 for the specific performance claims as verified and substantiated by test data.

This filter improves the taste and odor and reduces many chemical contaminants in drinking water. The faucet indicator monitors the length of time the filter has been installed and will flash amber continuously, indicating that the battery and the filters need to be replaced.

This system has been tested according to NSF/ANSI 42 and 53 for the reduction of the substances listed below. The concentration of the indicated substances in water entering the system was reduced to a concentration less than or equal to the permissible limit for water leaving the system, as specified in NSF/ANSI 42 and 53. The testing was performed using spiked tap water at a flow rate of 0.5 GPM (1.89 L/min.), pH of 7.5 ±0.5, pressure of 60 PSIG, and temperature of 68 ±5°F.

**IMPORTANT NOTICE:** Read this performance data and compare the capabilities of this unit with your actual water treatment needs. It is recommended that, before purchasing a water treatment unit, you have your water supply tested to determine your actual water treatment needs. This filter system is designed to be used for the reduction of the performance claims listed below. Do not use where water is microbiologically unsafe or of unknown quality, without adequate disinfection before or after the system. Systems certified for cyst reduction may be used on disinfected water that may contain filterable cysts. While testing was performed under standard laboratory conditions, actual performance of the system may vary based on local water conditions. Some or all of the contaminants reduced by this unit may not be in your water supply. **See elsewhere in this manual for instructions on filter cartridge replacement, system installation, operating procedures, and warranty. The maintenance instructions must be followed for the product to perform as indicated below.**

**NOTE:** See labels on the water treatment system for additional information.

PERFORMANCE CLAIMS						
Contaminant	Required Influent Level (mg/L) <sup>②</sup>	NSF Max. Permissible Effl. Level (mg/L) <sup>②</sup>	Average Influent Level (mg/L) <sup>②</sup>	Avg. / Max. Effluent Level (mg/L) <sup>②</sup>	Avg. / Min. Percent Removal	EPA <sup>①</sup> Max. Contaminant Level (mg/L) <sup>②</sup>
Cyst	≥50,000 #/mL <sup>④⑤</sup>	99.95% <sup>③</sup>	93,000 #/mL <sup>④</sup>	<1 / <4 #/mL <sup>④</sup>	99.99 / 99.99	None <sup>⑥</sup>
Lead @ pH 6.5	0.15 ±10%	0.010	0.152	0.001 / 0.001	99.3 / 99.3	0.015
Lead @ pH 8.5	0.15 ±10%	0.010	0.150	0.001 / 0.001	99.3 / 99.3	0.015
Methyl tert-Butyl Ether (MTBE)	0.015 ±20%	0.005	0.01467	0.0005 / 0.0005	96.2 / 96.2	None <sup>⑥</sup>
<b>Substance</b>						
Chlorine Taste & Odor	2.0 ±10%	50% <sup>③</sup>	2.0	0.05 / 0.08	97.5 / 96.2	None <sup>⑥</sup>
<b>VOC Reduction<sup>⑦</sup></b>						
Chloroform	0.30 ±10%	95% <sup>③</sup>	0.320	0.0005 / 0.0005	99.8 / 99.8	0.080

① Environmental Protection Agency maximum contaminant level as required under the Safe Drinking Water Act.

② Milligrams per liter, which is equivalent to parts per million (PPM).

③ NSF minimum percent reduction requirement. The acceptance level for this substance is based on percent reduction, rather than maximum effluent concentration.

④ Particles per milliliter.

⑤ Microspheres were used as a surrogate.

⑥ The EPA has not determined a maximum contaminant level for this chemical.

⑦ Chloroform was used as a surrogate for the reduction of chemicals specified in the Organic Chemicals Reduced by Chloroform Surrogate Testing table (on the following page).

# Performance Claims (continued)

## ORGANIC CHEMICALS REDUCED BY CHLOROFORM SURROGATE TESTING

Contaminant	Average Influent (µg/L) <sup>②</sup>	Maximum Effluent (µg/L) <sup>②</sup>	Percent Removal	EPA MCL <sup>⑦</sup> (µg/L) <sup>②</sup>
Alachlor	50	1.0 <sup>③</sup>	>98	2.0
Atrazine	100	3.0 <sup>③</sup>	>97	3.0
Benzene	81	1.0 <sup>③</sup>	99	5.0
Carbofuran	190	1.0 <sup>③</sup>	>99	40
Carbon Tetrachloride	78	1.8 <sup>④</sup>	98	5.0
Chlorobenzene	77	1.0 <sup>③</sup>	99	100
Chloropicrin	15	0.2 <sup>④</sup>	99	NA
2,4-D	110	1.7 <sup>④</sup>	98	70
Dibromochloropropane (DBCP)	52	0.02 <sup>③</sup>	>99	0.2
o-Dichlorobenzene	80	1.0 <sup>③</sup>	99	600
p-Dichlorobenzene	40	1.0 <sup>③</sup>	98	75
1,2-Dichloroethane	88	4.8 <sup>⑤</sup>	95 <sup>⑤</sup>	5.0
1,1-Dichloroethylene	83	1.0 <sup>③</sup>	99	7.0
cis-1,2-Dichloroethylene	170	0.5 <sup>③</sup>	>99	70
trans-1,2-Dichloroethylene	86	1.0 <sup>③</sup>	99	100
1,2-Dichloropropane	80	1.0 <sup>③</sup>	99	5.0
cis-1,3-Dichloropropylene	79	1.0 <sup>③</sup>	99	NA
Dinoseb	170	0.2 <sup>④</sup>	99	7.0
Endrin	53	0.59 <sup>④</sup>	99	2.0
Ethylbenzene	88	1.0 <sup>③</sup>	99	700
Ethylene Dibromide (EDB)	44	0.02 <sup>③</sup>	>99	0.05
Haloacetonitriles (HAN):				
Bromochloroacetonitrile	22	0.5 <sup>④</sup>	98	NA
Dibromoacetonitrile	24	0.6 <sup>④</sup>	98	NA
Dichloroacetonitrile	9.6	0.2 <sup>④</sup>	98	NA
Trichloroacetonitrile	15	0.3 <sup>④</sup>	98	NA

Contaminant	Average Influent (µg/L) <sup>②</sup>	Maximum Effluent (µg/L) <sup>②</sup>	Percent Removal	EPA MCL <sup>⑦</sup> (µg/L) <sup>②</sup>
Haloketones (HK):				
1,1-Dichloro-2-propanone	7.2	0.1 <sup>④</sup>	99	NA
1,1,1-Trichloro-2-propanone	8.2 <sup>⑥</sup>	0.3 <sup>④</sup>	96	NA
Heptachlor	25	0.01 <sup>③</sup>	>99	0.4
Heptachlor Epoxide	10.7 <sup>⑥</sup>	0.2 <sup>⑥</sup>	98	0.2
Hexachlorobutadiene	44	1.0 <sup>③</sup>	98	NA
Hexachlorocyclopentadiene	60	0.002 <sup>③</sup>	>99	50
Lindane	55	0.01 <sup>③</sup>	>99	0.2
Methoxychlor	50	0.1 <sup>③</sup>	>99	40
Pentachlorophenol	96	1.0 <sup>③</sup>	99	1.0
Simazine	120	4.0 <sup>③</sup>	97	4.0
Styrene	150	0.5 <sup>③</sup>	>99	100
1,1,2,2-Tetrachloroethane	81	1.0 <sup>③</sup>	99	NA
Tetrachloroethylene	81	1.0 <sup>③</sup>	99	5.0
Toluene	78	1.0 <sup>③</sup>	99	1,000
2,4,5-TP (Silvex)	270	1.6 <sup>③</sup>	99	50
Tribromoacetic Acid	42	1.0 <sup>③</sup>	98	NA
1,2,4-Trichlorobenzene	160	0.5 <sup>③</sup>	>99	70
1,1,1-Trichloroethane	84	4.6 <sup>④</sup>	95	200
1,1,2-Trichloroethane	150	0.5 <sup>③</sup>	>99	5.0
Trichloroethylene	180	1.0 <sup>③</sup>	>99	5.0
Trihalomethanes (incl.):				
Chloroform (surrogate chemical)	300	15	95	80
Bromoform				
Bromodichloromethane				
Chlorodibromomethane				
Xylenes (total)	70	1.0 <sup>③</sup>	99	10,000

- ① Influent challenge levels are average influent concentrations determined in surrogate qualification testing.
- ② Micrograms per liter, which is equivalent to parts per billion (PPB).
- ③ Maximum product water level was not observed but set at the detection limit of the analysis.
- ④ Maximum product water level set at a value determined in surrogate qualification testing.
- ⑤ Chemical reduction percent and maximum product water level calculated at chloroform 95% breakthrough point, as determined in surrogate qualification testing.
- ⑥ The surrogate test results for Heptachlor Epoxide demonstrated a 98% reduction. These data were used to calculate an upper occurrence concentration, which would produce a maximum product water level at the MCL.
- ⑦ Environmental Protection Agency maximum contaminant level as required under the Safe Drinking Water Act.

---

# Before You Start

- ▼ Read all steps and guides carefully before installing and using your water filtration system. Follow all steps exactly to correctly install. Reading this manual will also help you to get all the benefits from the water filtration system.
- ▼ Do not use with water that is microbiologically unsafe or of unknown quality without adequate disinfection before or after the system. This system is certified for cyst reduction and may be used on disinfected waters that may contain filterable cysts.
- ▼ All plumbing should be done in accordance with local codes and requirements. In Massachusetts, plumbing code 248 CMR 3.00 and 10.00 shall be adhered to. Consult with your licensed plumber.
- ▼ The water filtration system works on water pressures of 30 psi (minimum) to 100 psi (maximum). If your house water pressure is over the maximum, install a pressure reducing valve in the water supply pipe to the filter system.
- ▼ Do not install the water filtration system outside, or in extreme hot or cold temperatures. The temperature of the water supply to the water filtration system must be between 40°F and 100°F. Do not install on hot water.

## Dimensions

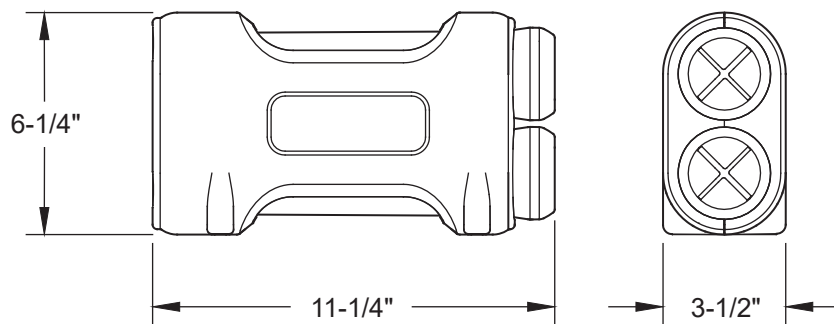

FIG. 1

**Questions? Call Toll Free 1-866-986-3223** or visit [whirlpoolwatersolutions.com](http://whirlpoolwatersolutions.com)

When you call, please be prepared to provide the model, date code and serial number, found on the rating decal on back.

---

# Parts of the System

- Filter system assembly
- Water supply fitting
- Filtered water faucet for sink or countertop mounting
- Color coded 3/8" tubing to make all needed connections
- Filter change drip tray

## Materials and Tools Needed

**NOTE:** Gather the required tools before starting installation. Read and follow the instructions provided with any tools listed here.

- Slotted and Phillips screwdrivers
- Pliers and adjustable jaw wrench
- Tubing cutter
- Electric drill and 1-1/4" drill bit if mounting hole is needed for the faucet

**IMPORTANT:** To avoid damaging the sink, consult a qualified plumber or installer for drilling procedures in porcelain or stainless steel.

## Typical Undersink Installation

Locate the water filter housing on the cold water supply pipe, under the kitchen and/or bathroom sink, to filter the cold drinking water. Refer to the following drawing.

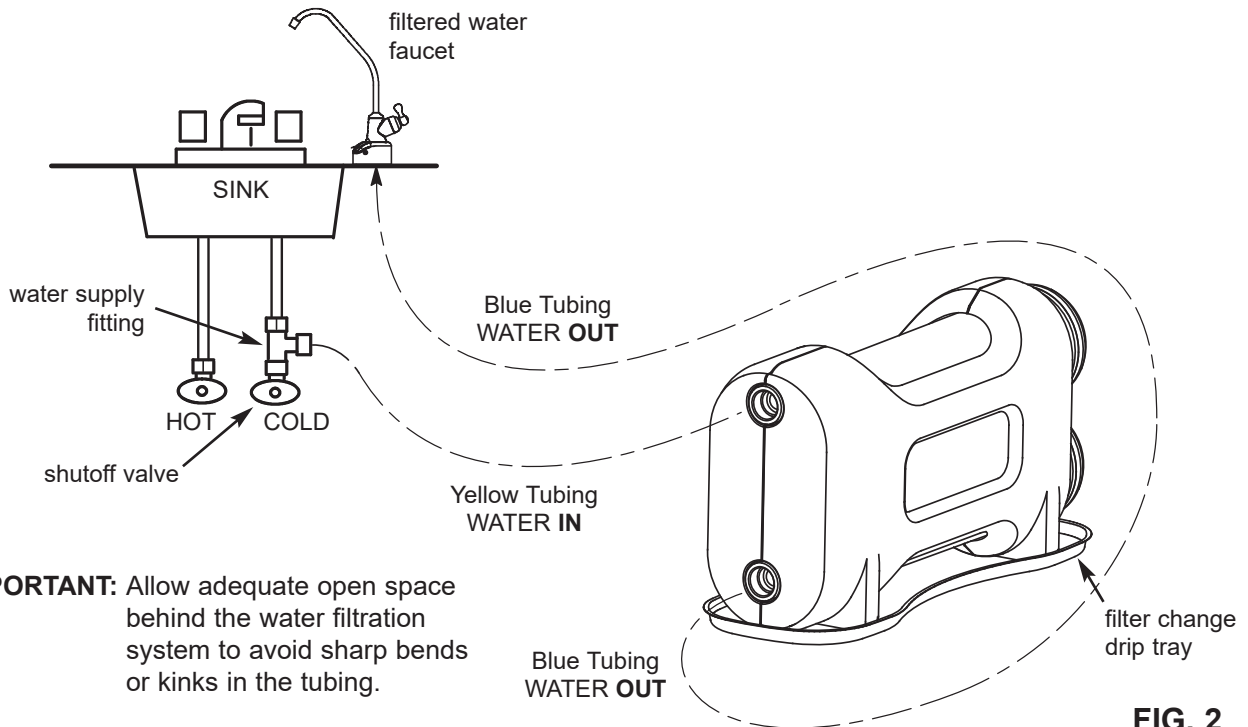

# Installation Instructions

## Step A - Install Cold Water Supply Fitting

Check and comply with local plumbing codes as you plan, then install a cold water supply fitting. The fitting must provide a leak-tight connection to the water filter 3/8" tubing. A typical connection using the included water supply fitting is shown in Figure 3A. An optional connection using standard plumbing fittings (not included) is shown in Figure 3B.

### Included Water Supply Fitting

1. Close the cold water shutoff valve (angle stop valve) that the water supply fitting will be installed on, and open faucet(s) to relieve pressure.
2. Disconnect the existing cold water line from the water shutoff valve.
3. Make sure that the water supply fitting's gasket is inside the female threaded portion of the fitting.
4. Install the water supply fitting onto the cold water shutoff valve, where the existing cold water line was removed, and hand tighten. Make sure not to cross thread or overtighten.
5. Connect the existing cold water line to the male threaded portion of the water supply fitting and hand tighten. Make sure not to cross thread or overtighten.

### Optional Pipe Fittings (compression type shown)

**NOTE:** Be sure to turn off the water supply and open a faucet to drain the pipe.

Complying with plumbing codes, install a fitting on the cold water pipe to adapt 3/8" OD tubing. A typical connection is shown in Figure 3B. If threaded fittings are used, be sure to use pipe joint compound or thread sealing tape on outside threads.

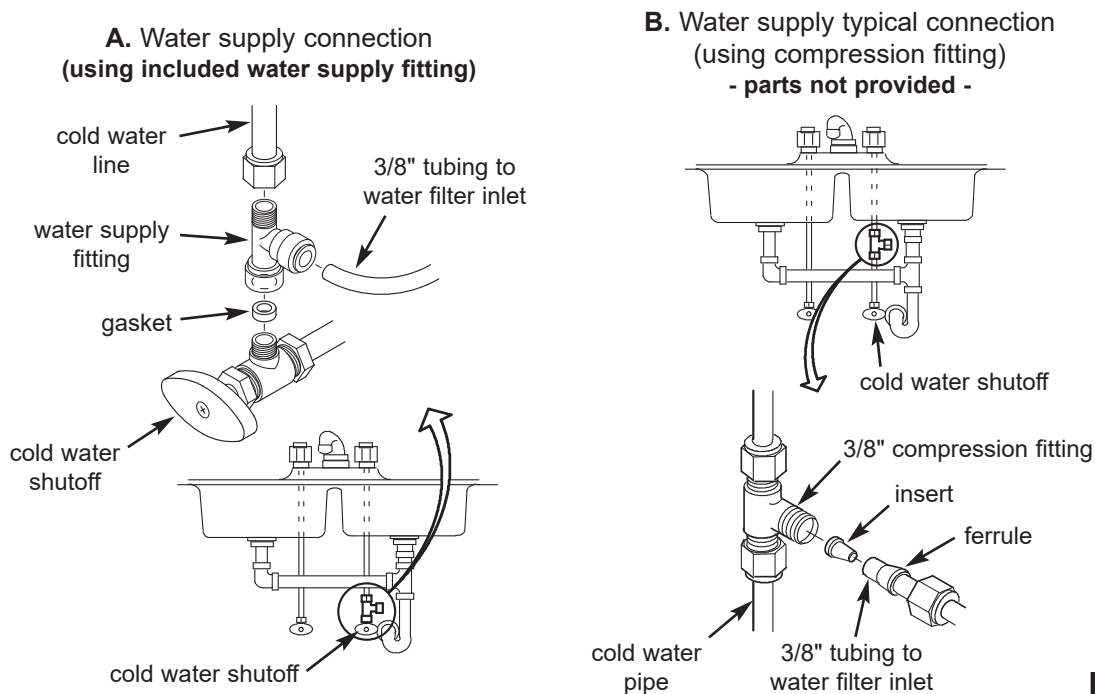

**FIG. 3**

## Step B - Make Hole For Filtered Water Faucet

**IMPORTANT:** To avoid damaging the sink, consult a qualified plumber or installer for drilling procedures in porcelain, stainless steel, or granite. Special drill bits are made for this.

1. Select one of the following places to install the faucet. Be sure there is room underneath so you can make the needed connections.
  - In an existing sink spray attachment hole.
  - Drill a hole in the sink top.
  - Drill a hole in the countertop next to the sink.
2. If drilling is needed make a 1-1/4" dia. (minimum) hole for the faucet.

---

# Installation Instructions

## Step C - Install Faucet

1. Insert one end of the 3/8" blue tubing into the push-in fitting on the bottom of the faucet. Push tubing through the collet and all the way into the fitting. Full engagement is 3/4" length of tube into the fitting.
2. Feed the 3/8" tubing that is attached to the faucet through the mounting hole. Slide the toggle bolts through the mounting hole. Tighten the screws to secure the base flat on the mounting surface. Do not overtighten.
3. Move the faucet down onto the base. Turn 1/4 clockwise to attach the faucet to the base.
4. Install battery in the base. See "Battery Change" section for instructions.

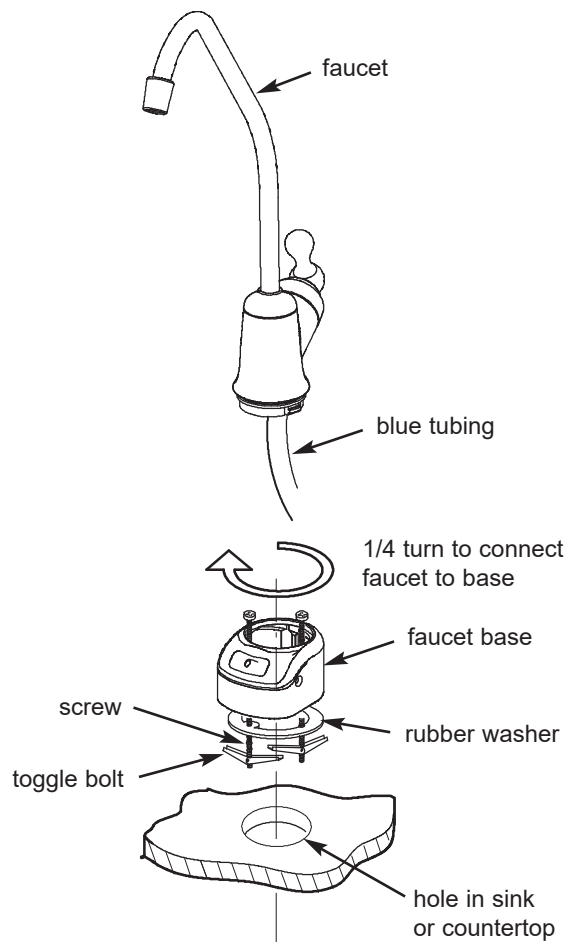

**FIG. 4**

## Step D - Make Tubing Connections

1. Allowing some slack, measure and cut a length of 3/8" tubing to connect between the supply fitting and the filter system inlet (See Figure 2). Cut the ends of the tubing square.
2. Insert tubing all the way into the supply fitting and inlet fitting. Pull on the tubing to be sure that it's held firmly in the fittings.
3. Repeat steps 1 and 2 to connect tubing from the faucet to the filter system outlet (See Figure 2).

Tubing Connection (all push-in fitting locations):

This system includes push-in fittings for quick tubing connections. If working with the fittings, do the following.

continued on the next page



# Installation Instructions

continued from the previous page

## Connect Tubing:

1. Use a box cutter or knife to cut the end of tubing square.
  2. Inspect the end (about 1") of the tubing to be sure there are no nicks, scratches, or other rough spots. If needed cut the tubing again.
  3. Push tubing through the collet and all the way into the fitting. Full engagement is 3/4" length of tube into the fitting.
- If tubing other than supplied with the system is used, be sure it is of high quality, exact size, and roundness with a smooth surface.

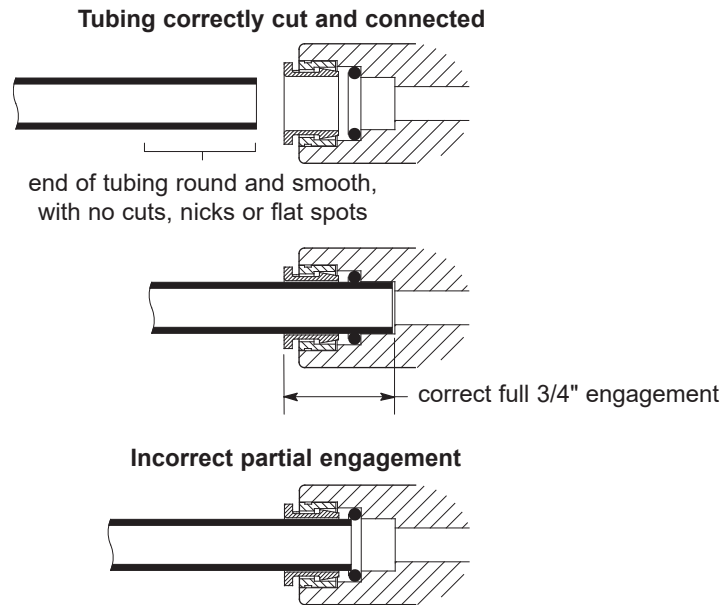

**FIG. 5**

## To Disconnect Tubing:

1. Push the collet inward and hold with a finger while pulling the tubing out.

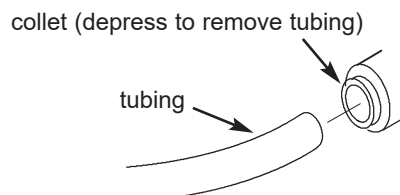

**FIG. 6**

## Step E - Turn On Water, Check for Leaks and Rinse Carbon Fines

1. Open the shutoff valve(s) that you closed at the beginning of this installation.
2. Open the sink faucet and filtered water faucet to purge air from the system. When the water runs smooth, with no bubbles or spurting, close faucets and check the installation for leaks.
3. Open the filtered water faucet and let the water run for 10 minutes to rinse out carbon fines.

**Questions? Call Toll Free 1-866-986-3223** or visit [whirlpoolwatersolutions.com](http://whirlpoolwatersolutions.com)

When you call, please be prepared to provide the model, date code and serial number, found on the rating decal on back.

---

# Filter Cartridges

## Filter Cartridge Life

**Taste and Odor Cartridges:** A taste and odor cartridge contains activated carbon, a black powder. When new, open the filtered water faucet and allow fine, carbon particles to purge from the cartridge. Close the faucet when you no longer see the “fines” (carbon particulates) in the filtered water, or approximately 10 minutes. It is recommended to replace the battery and filter cartridges every six months of use. There are several variables that determine how long a cartridge will last. These include:

1. How much water you use, and
2. How much sediment, taste and/or odor, or other unwanted substance, is in the water.

Use the following information as a guide. However, no matter which type of cartridge you are using, you will know it is time to replace it when you first notice the return of the unwanted substance in your water.

Whirlpool® Dual Stage Water Filtration System model WHADUS5 with replacement element pack WHEEDF conforms to NSF/ANSI 42 and 53 for the specific performance claims as verified and substantiated by test data. The rated capacity for this system is 270 gallons (1022 liters) at a rated service flow of 0.5 gallons per minute.

**Register for reminders to change filters at  
[whirlpoolwatersolutions.com](http://whirlpoolwatersolutions.com)**

## Filter Cartridge Replacement

1. Turn the filter cartridge counterclockwise to remove cartridges from the filter manifold.  
**NOTE:** You may notice some water under the system during filter change.
2. Dispose of the cartridges in a proper manner.
3. Install new cartridges. Turn cartridges clockwise to re-attach to the filter manifold.
4. Remove and replace the timer battery. See “Battery Change” section for instructions.

**Taste and Odor Cartridges:** A taste and odor cartridge contains activated carbon, a black powder. When new, open the filtered water faucet and allow the fine carbon particles to purge from the cartridge. Close the faucet when you no longer see the “fines” in the filtered water or approximately 10 minutes.

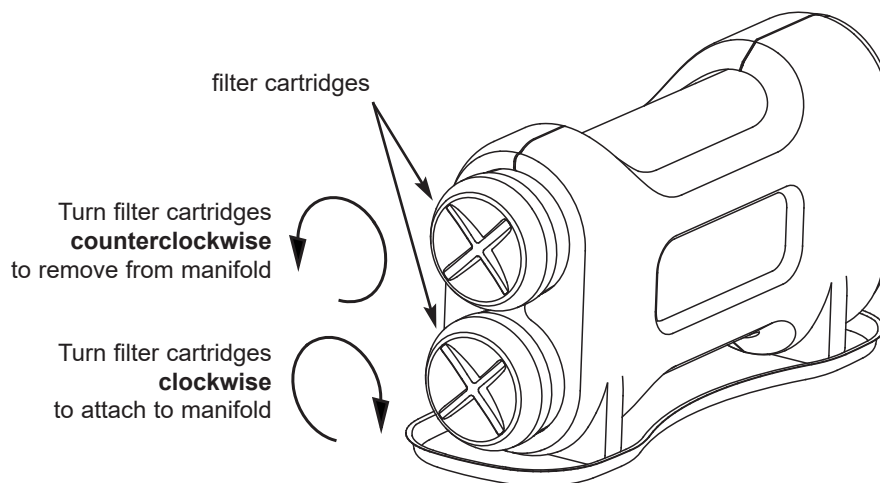

**FIG. 7**

# Faucet Electronics

## Faucet Timer

Inside the faucet base is a battery operated 6 month timer.

An amber LED indicator is also located in the front of the faucet base. This LED will flash continuously after 6 months have passed. This indicates that it is time to replace the battery and filters.

## Battery Change

To change the battery, complete the following steps.

1. Loosen the screw on the right side of the faucet base.
2. Press the battery housing upwards from the faucet base until it releases from the base.
3. Replace the battery (CR 2032 or equivalent). Place battery into the holder with the positive (+) side facing the back of the holder.
4. When the battery is first replaced the light in the base will flash six times and turn off. This indicates the battery is fully charged. After the six flashes, the timer enters the 6 month time cycle. If it repeatedly flashes two times, the battery is weak and needs to be replaced.
5. Re-install the battery housing and firmly tighten the mounting screw.

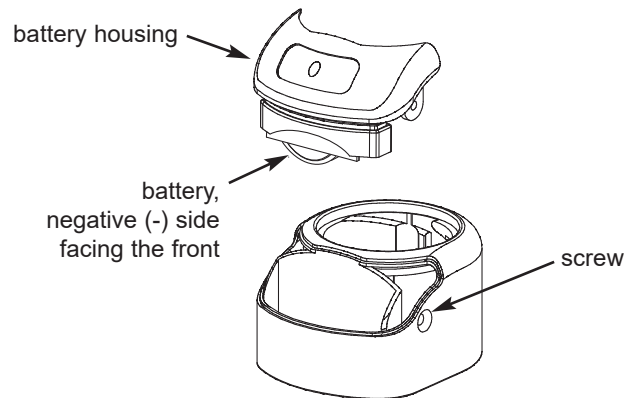

FIG. 8

## Troubleshooting the System

<b><i>Problem: Taste and/or Odor.</i></b>	
<b><i>Cause:</i></b> Pre & Post filter expended.	<b><i>Correction:</i></b> Replace the filter cartridges.
<b><i>Cause:</i></b> System contaminated.	<b><i>Correction:</i></b> Sanitize system. Call 1-866-986-3223 for instructions.
<b><i>Problem: Faucet LED indicator light does not function after battery change.</i></b>	
<b><i>Cause:</i></b> Battery dead.	<b><i>Correction:</i></b> Replace with new battery.
<b><i>Cause:</i></b> Battery installed incorrectly.	<b><i>Correction:</i></b> Install battery correctly.
<b><i>Problem: Water leaks at push connect fittings.</i></b>	
<b><i>Cause:</i></b> Tubing not pushed in all the way.	<b><i>Correction:</i></b> Push tubing in all the way into fittings.
<b><i>Cause:</i></b> Tubing not cut square.	<b><i>Correction:</i></b> Cut tubing square.
<b><i>Cause:</i></b> Tubing nicked.	<b><i>Correction:</i></b> Remove nicked portion, reinsert tubing into fitting.
<b><i>Cause:</i></b> Outer tubing surface not smooth.	<b><i>Correction:</i></b> Remove rough portion, reinsert tubing into fitting.

**Need help troubleshooting?**  
**Call Toll Free 1-866-986-3223 or visit [whirlpoolwatersolutions.com](http://whirlpoolwatersolutions.com)**

# Parts List

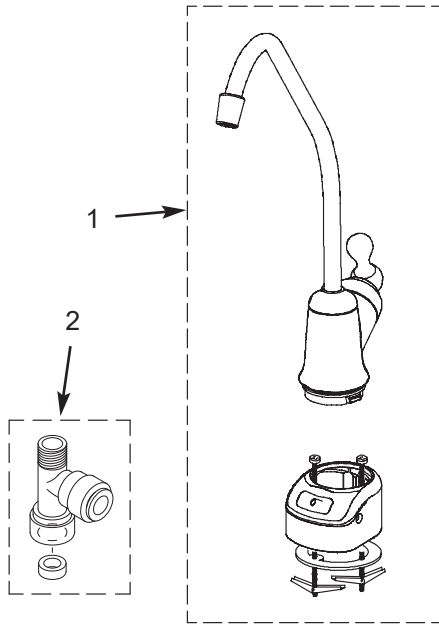

Key No.	Part No.	Description
1	7292674	Faucet, with base & electronics
2	119-8600088	Water Supply Fitting, 3/8" Q.C.
-	1128-03-HD	Repl. Cabinet (incl. Key Nos. 3 & 4)
3	↑	Cabinet, Left
4	↑	Cabinet, Right
5	1128-03-HB	Manifold Assembly (includes Key Nos. 3-5)
6	WHEEDF	Repl. Filter Cartridge (2 pack) *
■	7168435	Tubing, 3/8" x 72" long, White
■	7387356	Owner's Manual

\* Please purchase replacement cartridges from the retailer where you bought your water filtration system.

■ Not illustrated.

To order repair parts call toll free 1-866-986-3223.

Manufactured and warranted by  
 Water Channel Partners  
 1890 Woodlane Drive  
 Woodbury, MN 55125

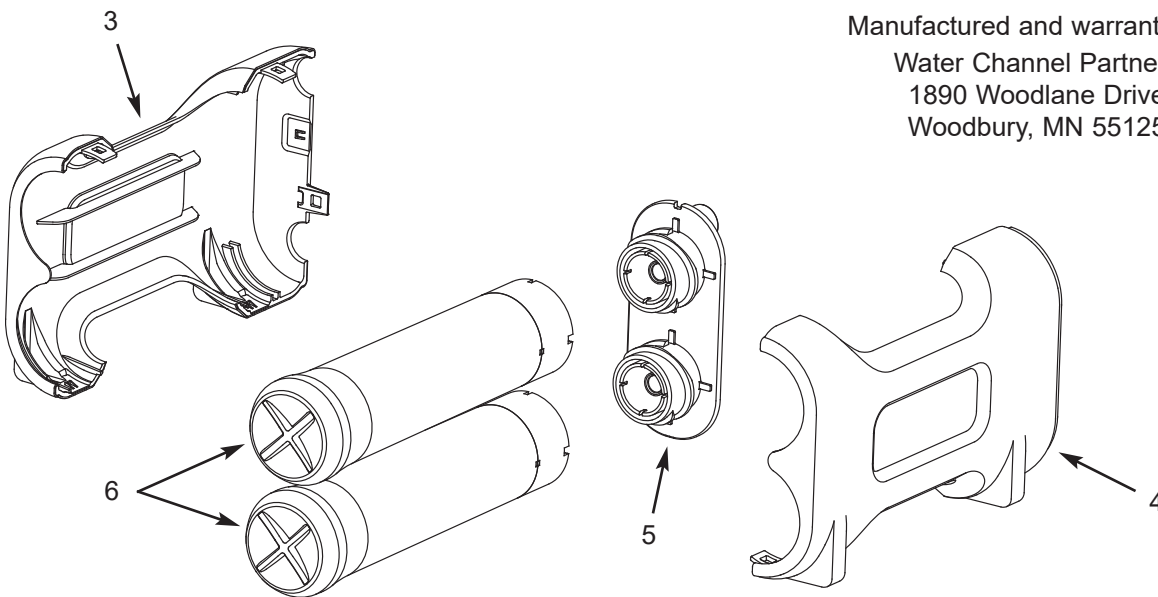

## EXTEND YOUR WARRANTY:

You can turn your R.O. system's one year factory warranty into a lifetime warranty by saving your receipts for purchases of Whirlpool® replacement R.O. membrane and filter cartridges. See "Lifetime Warranty" below for details.

### WARRANTY

#### DUAL STAGE WATER FILTRATION SYSTEM - MODEL WHADUS5 (not including filter cartridges)

**Warrantor: Water Channel Partners, 1890 Woodlane Drive, Woodbury, MN 55125**

##### One Year Warranty:

Warrantor guarantees, to the original purchaser when the product is purchased from an authorized dealer, and when installed and maintained in accordance with the instructions, that the Dual Stage Water Filtration System (WHADUS5) will be free from defects in materials and workmanship and will perform in accordance with its written specifications for a period of one (1) year from the date the product is delivered.

##### Lifetime Warranty:

Warrantor guarantees, to the original purchaser only, that the Dual Stage Water Filtration System (WHADUS5) will be free from defects in materials and workmanship and will perform in accordance with its written specifications for the lifetime of the purchaser, provided that:

- The product is purchased from an authorized dealer.
- The system is installed and maintained in accordance with the instructions in the same home where it was originally installed.
- The purchaser replaces both filters every six (6) months and saves their receipts, for proof of purchase of the Whirlpool WHEEDF filter cartridge set, in case a warranty claim is made. Purchase of no more than two (2) WHEEDF filter sets in a 12 month period may be applied toward compliance with this warranty.

Failure to adhere to the above requirements from the date the product is delivered voids the lifetime warranty.

If, during such respective period, a part proves, after inspection, to be defective, Warrantor will, at its sole option, either replace or repair the part without charge except normal shipping and installation charges. If a repair or replacement part is unavailable, Warrantor may refund the original purchase price. Labor necessary to maintain this product is not covered by the product warranty. Filter cartridges, which are expendable, are not covered by the warranty.

If you have questions regarding a warranted product, need assistance with installation or troubleshooting, wish to order a part or report a warranty issue, we are just a phone call away. SIMPLY DIAL 1-866-986-3223 for assistance.

##### General Provisions

The above warranties are effective provided the Dual Stage Water Filtration System is operated at water pressures not exceeding 100 psi (7.0 kg/cm<sup>2</sup>), and at water temperatures not exceeding 100°F (38°C); provided further that the Dual Stage Water Filtration System is not subject to abuse, misuse, alteration, neglect, freezing, accident or negligence; and provided further that the Dual Stage Water Filtration System is not damaged as the result of any force of nature such as, but not limited to, flood, hurricane, tornado or earthquake.

The limited warranty does not cover damage due to: (a) transportation, (b) storage, (c) improper use, (d) failure to follow the product instructions or to perform any preventive maintenance, (e) modifications, (f) unauthorized repair, (g) normal wear and tear, or (h) external causes such as accidents, abuse, or other actions or events beyond Warrantor's reasonable control. Use of aftermarket, used, or non-manufacturer provided parts will void all warranties. Warranty does not cover failures due to improper product installation. Warrantor is excused if failure to perform its warranty obligations is the result of strikes, government regulation, materials shortages, or other circumstances beyond its control.

THERE ARE NO WARRANTIES ON THE DUAL STAGE WATER FILTRATION SYSTEM BEYOND THOSE SPECIFICALLY DESCRIBED ABOVE. ALL IMPLIED WARRANTIES, INCLUDING ANY IMPLIED WARRANTY OF MERCHANTABILITY OR OF FITNESS FOR A PARTICULAR PURPOSE, ARE DISCLAIMED TO THE EXTENT THEY MIGHT EXTEND BEYOND THE ABOVE PERIODS. THE SOLE OBLIGATION OF WARRANTOR UNDER THESE WARRANTIES IS TO REPLACE OR REPAIR THE COMPONENT OR PART WHICH PROVES TO BE DEFECTIVE WITHIN THE SPECIFIED TIME PERIOD, AND WARRANTOR IS NOT LIABLE FOR CONSEQUENTIAL OR INCIDENTAL DAMAGES. NO DEALER, AGENT, REPRESENTATIVE, OR OTHER PERSON IS AUTHORIZED TO EXTEND OR EXPAND THE WARRANTIES EXPRESSLY DESCRIBED ABOVE.

Some states do not allow the exclusion or limitation of incidental or consequential damages, so the above limitation or exclusion may not apply to you. This warranty gives you specific legal rights, and you may have other rights which vary from state to state. This warranty applies to consumer-owned installations only.

® / ™ © 2024 Whirlpool. All rights reserved.

Manufactured under license by Water Channel Partners, Woodbury, Minnesota.

Warranty provided by manufacturer.