



## Model WHESFC

How to install, operate  
and maintain your  
Water Conditioner



# Installation and Operation Manual

Do not return system to store

If you have any questions or concerns when installing, operating or maintaining your water conditioner, call our toll free number:

**1-866-986-3223**

or visit **[whirlpoolwatersolutions.com](http://whirlpoolwatersolutions.com)**

When you call, please be prepared to provide the model and serial number of your product, found on the rating decal, typically located on the rim below the salt lid hinges.

System tested and certified by NSF International against NSF/ANSI Standard 42 for the reduction of chlorine taste and odor, and Standard 44 for hardness reduction and efficiency, and certified to NSF/ANSI Standard 372.



Manufactured and warranted by  
Ecodyne Water Systems  
1890 Woodlane Drive  
Woodbury, MN 55125

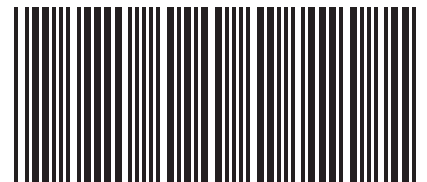

7346075 (Rev. F 6/13/17)

---

## TABLE OF CONTENTS

	<u>Page</u>
Specifications & Performance Claims .....	3
Water Conditioner Safety .....	4
Before You Start .....	4
Inspect Shipment .....	5
Water Conditioning Information .....	5
Installation Requirements .....	6-7
Dimensions .....	8
Installation Instructions .....	8-12
Programming the Water Conditioner .....	13-14
Customizing Features / Options .....	15-18
Routine Maintenance .....	18-19
Troubleshooting .....	20-21
Exploded View & Parts List .....	22-25
Warranty .....	26

## Specifications & Performance Claims

This model is efficiency rated. The efficiency rating is valid only at the minimum salt dose and rated service flow. This system has a demand initiated regeneration (D.I.R.) feature that complies with specific performance specifications intended to minimize the amount of regenerant brine and water used in their operation.

This water conditioner has a rated softener efficiency of not less than 3,350 grains of total hardness exchange per pound of salt (based on sodium chloride) and shall not deliver more salt than its listed rating or be operated at a sustained maximum service flow rate greater than its listed rating. This system has been proven to deliver soft water for at least ten continuous minutes at the rated service flow rate. The rated salt efficiency is measured by laboratory tests described in NSF/ANSI Standard 44. These tests represent the maximum possible efficiency that the system can achieve. Operational efficiency is the actual efficiency after the system has been installed. It is typically less than the rated efficiency, due to individual application factors including water hardness, water usage, and other contaminants that reduce a softener's capacity.

While testing was performed under standard laboratory conditions, actual performance of the system may vary based on local water conditions. This system has been tested according to NSF/ANSI Standard 42 for the reduction of chlorine taste and odor. The concentration of the indicated substance in water entering the system was reduced to a concentration less than or equal to the permissible limit for water leaving the system, as specified in NSF/ANSI Standard 42.

continued on next page

# Specifications & Performance Claims

SPECIFICATIONS											
	<b>Model WHESFC</b>										
Model Code	LLFC										
Rated Softening Capacity (Grains @ Salt Dose)	11,000 @ 2.6 lbs. 24,700 @ 7.8 lbs. 31,100 @ 13.4 lbs.										
Rated Efficiency (Grains/Pound of Salt @ Minimum Salt Dose)	4,230 @ 2.6 lbs.										
Water Used During Regeneration @ Minimum Salt Dose	4.3 gal. / 1,000 grains										
Total Water Used Per Regeneration @ Maximum Salt Dose	54.7 gallons										
Rated Service Flow Rate	8.0 gpm										
Amount of High Capacity Ion Exchange Resin	0.98 cu. ft.										
Pressure Drop at Rated Service Flow	6.5 psig										
Water Supply Max. Hardness	120 gpg										
Water Supply Max. Clear Water Iron	3 ppm*										
Water Pressure Limits (min. / max.)	20 - 125 psi										
Water Temperature Limits (min. / max.)	40 - 100 °F										
Minimum Water Supply Flow Rate	3 gpm										
Intermittent Flow @ 15 PSI	13.7 gpm**										
Maximum Drain Flow Rate	2 gpm										
Salt Storage Capacity	200 lbs.										
Rated Capacity at Chlorine Concentration*** of:	<table border="0"> <tr> <td>0.50 ppm</td> <td>2,280,000 gal. §</td> </tr> <tr> <td>0.75 ppm</td> <td>1,520,000 gal. §</td> </tr> <tr> <td>1.0 ppm</td> <td>1,140,000 gal. §</td> </tr> <tr> <td>1.5 ppm</td> <td>760,000 gal. §</td> </tr> <tr> <td>2.0 ppm</td> <td>570,000 gal. §</td> </tr> </table>	0.50 ppm	2,280,000 gal. §	0.75 ppm	1,520,000 gal. §	1.0 ppm	1,140,000 gal. §	1.5 ppm	760,000 gal. §	2.0 ppm	570,000 gal. §
0.50 ppm	2,280,000 gal. §										
0.75 ppm	1,520,000 gal. §										
1.0 ppm	1,140,000 gal. §										
1.5 ppm	760,000 gal. §										
2.0 ppm	570,000 gal. §										

\*Capacity to reduce clear water iron is substantiated by laboratory test data. State of Wisconsin requires additional treatment if water supply contains clear water iron exceeding 5 ppm.

\*\*Intermittent flow rate does not represent the maximum service flow rate used for determining the conditioner's rated capacity and efficiency. Continuous operation at flow rates greater than the service flow rate may affect capacity and efficiency performance.

\*\*\*Typical residential chlorine concentration is 0.5 to 1.0 ppm.

§ From independent laboratory test data.

This system conforms to NSF/ANSI Standards 42 & 44 for the specific performance claims as verified and substantiated by test data.

**Variable Salt Dose:** The salt dose is selected by the electronic controls at regeneration time based on the amount needed.

PERFORMANCE CLAIMS		
Substance	Influent Challenge Level	Reduction Requirement
Chlorine	2.0 ±10% mg/L	50%

**Questions? Call Toll Free 1-866-986-3223** or visit [whirlpoolwatersolutions.com](http://whirlpoolwatersolutions.com)

When you call, please be prepared to provide the model and serial number, found on the rating decal, typically located on the rim below the salt lid hinges.

# Water Conditioner Safety

## Your safety and the safety of others are very important.

We have provided many safety messages in this manual and on your appliance. Always read and obey all safety messages.



This is the safety alert symbol.

This symbol alerts you to potential hazards that can kill or hurt you and others.

All safety messages will follow the safety alert symbol and either the word "DANGER" or "WARNING". These words mean:

**⚠ DANGER**

**You can be killed or seriously injured if you don't immediately follow instructions.**

**⚠ WARNING**

**You can be killed or seriously injured if you don't follow instructions.**

All safety messages will tell you what the potential hazard is, tell you how to reduce the chance of injury, and tell you what can happen if the instructions are not followed.

In the state of Massachusetts: The Commonwealth of Massachusetts plumbing code 248-CMR shall be adhered to. A licensed plumber shall be used for this installation.

In the state of California: You must turn the Salt Efficiency Feature setting to ON. This may initiate more frequent recharges. However, it will operate at 4,000 grains per pound of salt or higher. To turn on the Salt Efficiency Feature, follow the instructions in the "Salt Efficiency" section of this manual.

## Before You Start

- The water conditioner requires a minimum water flow of 3 gallons per minute at the inlet. Maximum allowable inlet water pressure is 125 psi. If daytime pressure is over 80 psi, nighttime pressure may exceed the maximum. Use a pressure reducing valve if necessary (Adding a pressure reducing valve may reduce the flow). If your home is equipped with a back flow preventer, an expansion tank must be installed in accordance with local codes and laws.
- Temperature of the water supply to the conditioner must be 40-100°F. Do not install on hot water.
- The water conditioner works on 24V DC electrical power, supplied by a direct plug-in power supply (included). Be sure to use the included power supply and plug it into a nominal 120V, 60 Hz household outlet that is in a dry location only, grounded and properly protected by an overcurrent device such as a circuit breaker or fuse.
- Do not use this system to treat water that is microbiologically unsafe or of unknown quality without adequate disinfection upstream or downstream of the system.



European Directive 2002/96/EC requires all electrical and electronic equipment to be disposed of according to Waste Electrical and Electronic Equipment (WEEE) requirements. This directive or similar laws are in place nationally and can vary from region to region. Please refer to your state and local laws for proper disposal of this equipment.

## Do not return the water conditioner to store.

If you have any questions, or there are missing parts or damage, please call **Toll Free 1-866-986-3223** or visit **[www.whirlpoolwatersolutions.com](http://www.whirlpoolwatersolutions.com)**

When you call, please be prepared to provide the model and serial number, found on the rating decal, typically located on the rim below the salt lid hinges.

# Inspect Shipment

The parts required to assemble and install the water conditioner are included with the unit. Thoroughly check the water conditioner for possible shipping damage and parts loss. Also inspect and note any damage to the shipping carton.

Remove and discard (or recycle) all packing materials. To avoid loss of small parts, we suggest you keep the small parts in the parts bag until you are ready to use them.

## Packing List

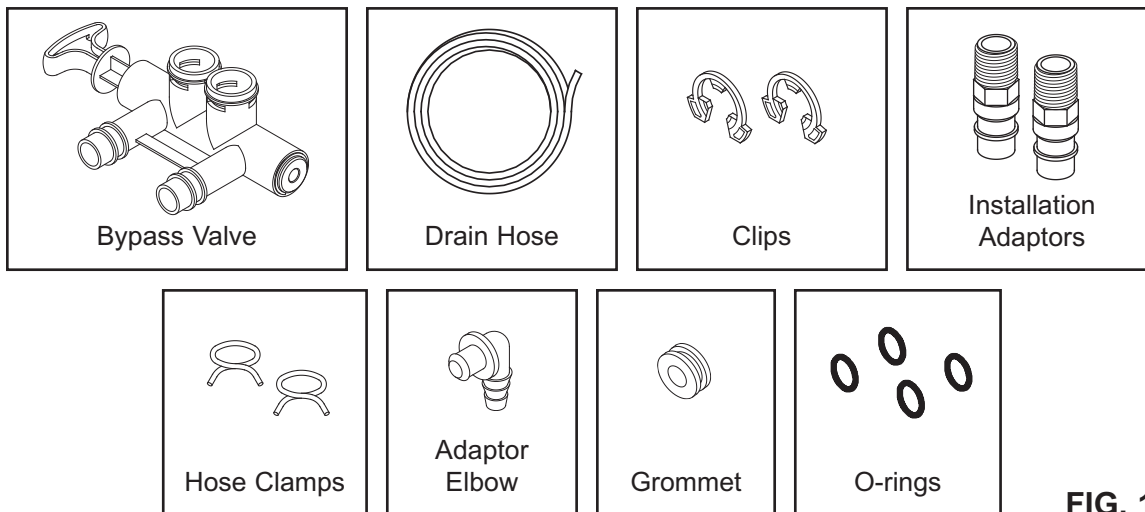

FIG. 1

## Water Conditioning Information

### IRON

Iron in water can cause stains on clothing and plumbing fixtures. It can negatively affect the taste of food, drinking water, and other beverages. Iron in water is measured in parts per million (ppm). The total\* ppm of iron, and type or types\*, is determined by chemical analysis. Four different types of iron in water are:

- Ferrous (clear water) iron
- Ferric (red water) iron
- Bacterial and organically bound iron
- Colloidal and inorganically bound iron (ferrous or ferric)

Ferrous (clear water) iron is soluble and dissolves in water. This water conditioner will reduce moderate amounts of this type of iron (see specifications).\*\*

Ferrous (clear water) iron is usually detected by taking a sample of water in a clear bottle or glass.

Immediately after taking, the sample is clear. As the water sample stands, it gradually clouds and turns slightly yellow or brown as air oxidizes the iron. This usually occurs in 15 to 30 minutes.

When using the conditioner to reduce Ferrous (clear water) iron, add 5 grains to the hardness setting for every 1 ppm of Ferrous (clear water) iron. See "Set Water Hardness Number" section.

Ferric (red water), and bacterial and organically bound irons are insoluble. This water conditioner will not remove ferric or bacterial iron. This iron is visible

immediately when drawn from a faucet because it has oxidized before reaching the home. It appears as small cloudy yellow, orange, or reddish suspended particles. After the water stands for a period of time, the particles settle to the bottom of the container. Generally these irons are removed from water by filtration. Chlorination is also recommended for bacterial iron.

Colloidal and inorganically bound iron is of ferric or ferrous form that will not filter or exchange out of water. This water conditioner will not remove colloidal iron. In some instances, treatment may improve colloidal iron water. Colloidal iron water usually has a yellow appearance when drawn. After standing for several hours, the color persists and the iron does not settle, but remains suspended in the water.

### SEDIMENT

Sediment is fine, foreign material particles suspended in water. This water conditioner will not remove sediment. This material is most often clay or silt. Extreme amounts of sediment may give the water a cloudy appearance. A sediment filter installed upstream of the water conditioner normally corrects this situation.

\* Water may contain one or more of the four types of iron and any combination of these. Total iron is the sum of the contents.

\*\* Capacity to reduce clear water iron is substantiated by WQA test data.

# Installation Requirements

## LOCATION REQUIREMENTS

Consider all of the following when selecting an installation location for the water conditioner.

- Do not locate the water conditioner where freezing temperatures occur. Temperature of the water supply to the conditioner must be 40-100°F. Do not install on hot water. Freezing temperatures or hot water damage voids the warranty.
- To condition all water in the home, install the water conditioner close to the water supply inlet, and upstream of all other plumbing connections, except outside water pipes. Outside faucets should remain on hard water to avoid wasting conditioned water and salt.
- A nearby drain is needed to carry away regeneration discharge (drain) water. Use a floor drain, laundry tub, sump, standpipe, or other options (check your local codes). See "Air Gap Requirements" and "Valve Drain Requirements" sections.
- The water conditioner works on 24V DC electrical power, supplied by a direct plug-in power supply (included). Provide nearby a 120V, 60 Hz electrical outlet in accordance with NEC and local codes.
- Always install the water conditioner between the water inlet and water heater. Any other installed water conditioning equipment should be installed between the water inlet and water conditioner (See Figure 3 below).
- Avoid installing in direct sunlight. Excessive sun heat may cause distortion or other damage to non-metallic parts.

## PLUMBING CODES

All plumbing must be completed in accordance with national, state and local plumbing codes.

In the state of Massachusetts: The Commonwealth of Massachusetts plumbing code 248-CMR shall be adhered to. A licensed plumber shall be used for this installation.

## AIR GAP REQUIREMENTS

A drain is needed for regeneration water (See Figure 2). A floor drain, close to the water conditioner, is preferred. A laundry tub, standpipe, etc. are other drain options. Secure valve drain hose in place. Leave an air gap of 1-1/2" between the end of the hose and the drain. This gap is needed to prevent backflow of sewer water into the water conditioner. Do not put the end of the drain hose into the drain.

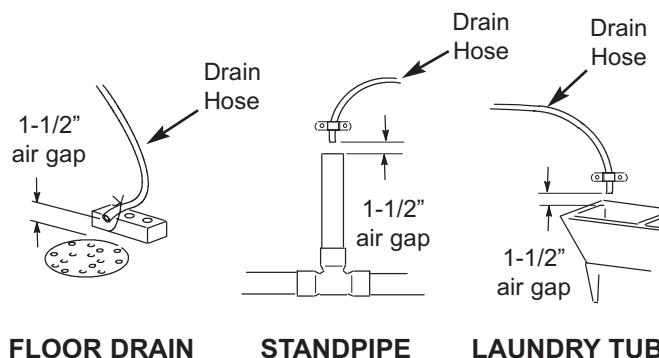

FIG. 2

## THE PROPER ORDER TO INSTALL WATER TREATMENT EQUIPMENT

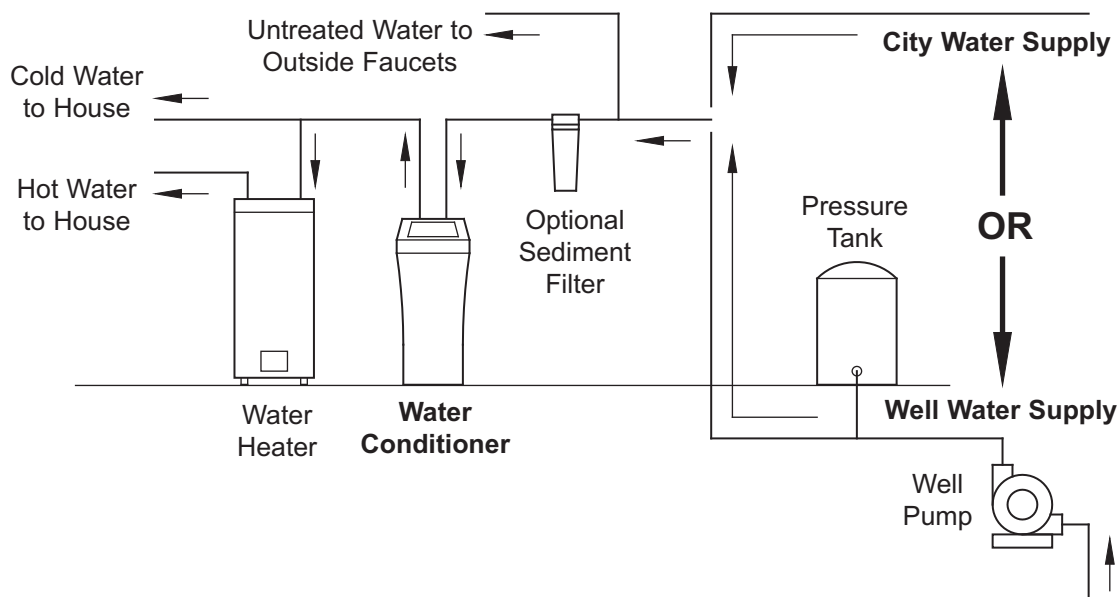

FIG. 3

# Installation Requirements

## VALVE DRAIN REQUIREMENTS

Using the flexible drain hose (included), measure and cut to the length needed. Flexible drain hose is not allowed in all localities (check your plumbing codes). If local codes do not allow use of a flexible drain hose, a rigid valve drain run must be used. Purchase a compression fitting (1/4 NPT x 1/2 in. minimum tube) and 1/2" tubing from your local hardware store. Plumb a rigid drain as needed (See Figure 5).

**NOTE:** Make the valve drain line as short and direct as possible.

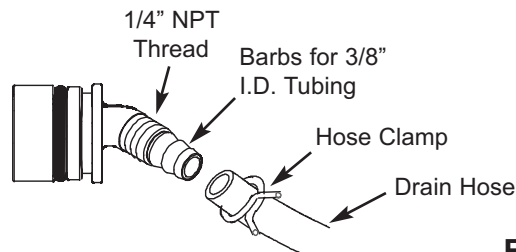

FIG. 4

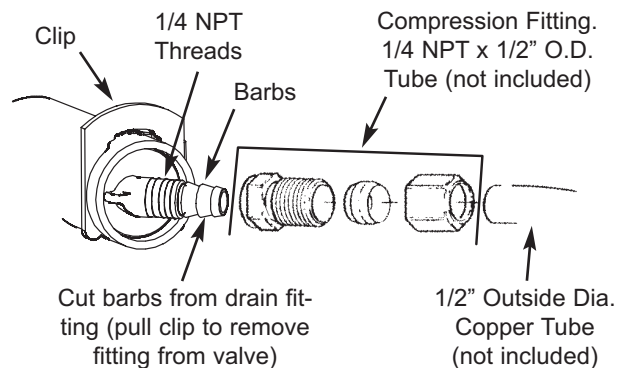

FIG. 5

**⚠ WARNING**

**Electrical Shock Hazard**

**Prior to installation on metallic plumbing, securely install two grounding clamps and a #4 copper wire per installation instructions.**

**Failure to follow these instructions can result in death or electrical shock.**

## INLET / OUTLET PLUMBING OPTIONS

Always install either a single bypass valve (provided), as shown in Figure 6, or, if desired, parts for a 3 valve bypass system (not included) can be purchased and assembled, as shown in Figure 7. Bypass valves allow you to turn off water to the conditioner for maintenance if needed, but still have water in house pipes. Pipe fittings must be 3/4" minimum.

Use:

- Copper pipe
- Threaded pipe
- PEX (Crosslinked Polyethylene) pipe
- CPVC plastic pipe
- Other pipe approved for use with potable water

**IMPORTANT:** Do not solder with plumbing attached to installation adaptors and single bypass valve. Soldering heat will damage the adaptors and valve.

### SINGLE BYPASS VALVE

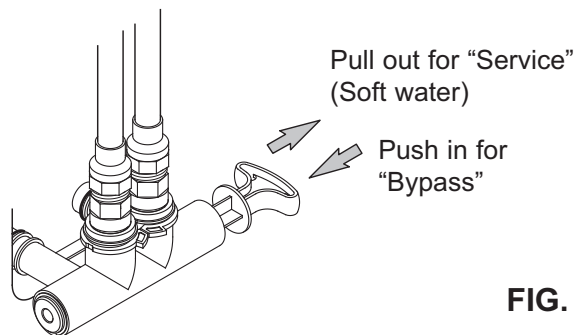

FIG. 6

### 3 VALVE BYPASS

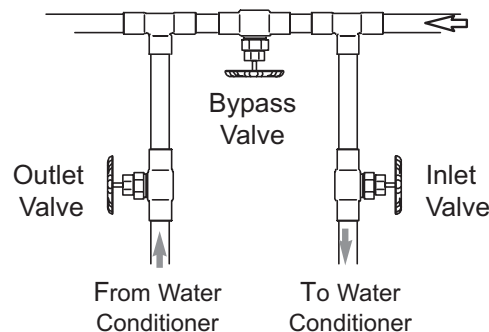

FIG. 7

# Dimensions

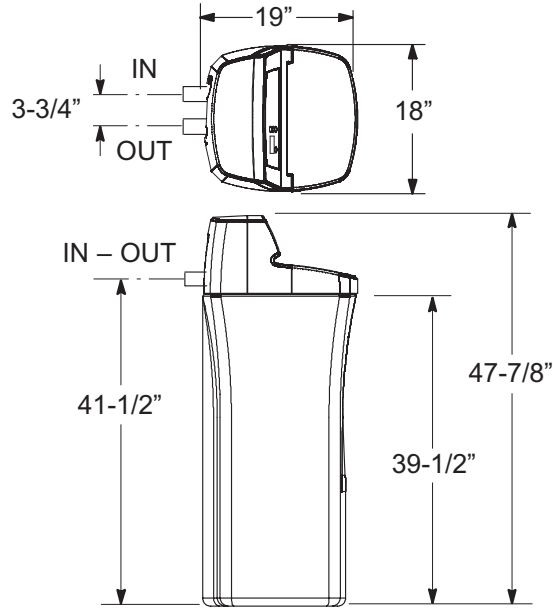

FIG. 8

# Installation Instructions

## TYPICAL INSTALLATION

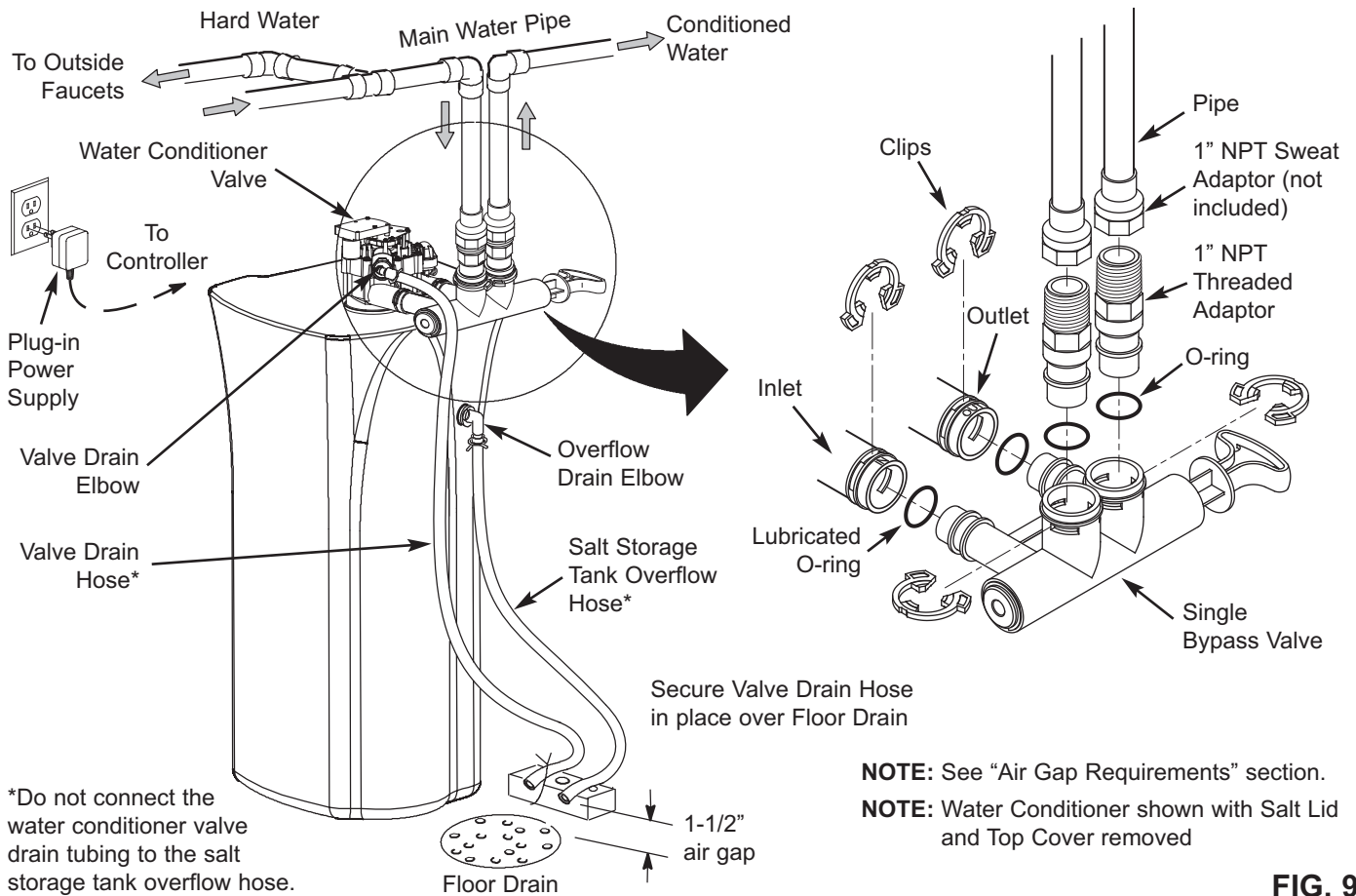

FIG. 9



# Installation Instructions

## TURN OFF WATER SUPPLY

1. Close the main water supply valve, located near the well pump or water meter.
2. Open all faucets to drain all water from house pipes.

**NOTE:** Be sure not to drain water from the water heater, as damage to the water heater elements could result.

## INSTALL THE BRINE TANK OVERFLOW ELBOW

Install the brine tank overflow grommet and elbow in the 13/16" diameter hole in the back of the salt storage tank sidewall.

**NOTE:** The brine tank overflow elbow accepts either 1/2" or 3/8" I.D. hose.

## MOVE THE WATER CONDITIONER INTO PLACE

### **WARNING**

#### Excessive Weight Hazard

Use two or more people to move and install water conditioner.

Failure to do so can result in back or other injury.

1. Move the water conditioner into the desired location. Set it on a solid, level surface.

**IMPORTANT:** Do not place shims directly under the salt storage tank to level the conditioner. The weight of the tank, when full of water and salt, may cause the tank to fracture at the shim.

2. Visually check and remove any debris from the water conditioner valve inlet and outlet ports.
3. Make sure the turbine assembly spins freely in the "out" port of the valve.
4. If not already done, put a light coating of silicone grease on the single bypass valve o-rings.
5. Push the single bypass valve into the conditioner valve as far as it will go. Snap the two large holding clips into place, from the top down as shown in Figures 11 & 12.

**IMPORTANT:** Be sure the clips snap firmly into place so the single bypass valve will not pull out.

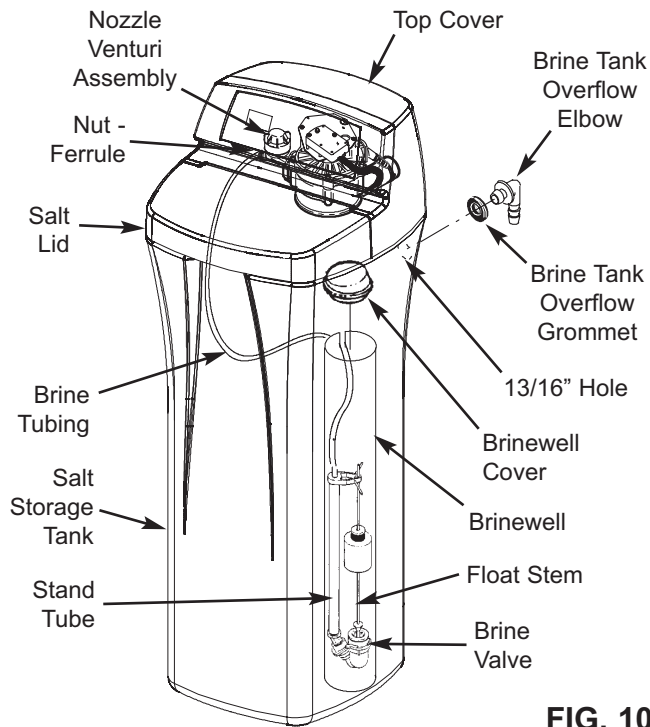

FIG. 10

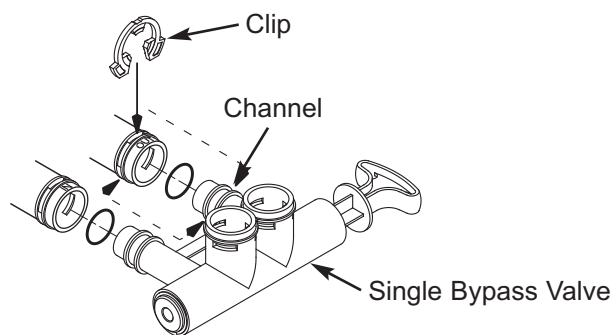

FIG. 11

### CORRECT ASSEMBLY

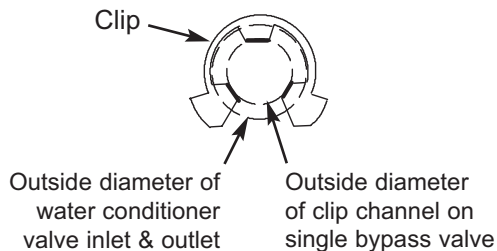

FIG. 12

**NOTE:** Be sure all 3 tabs of the clip go through the matching holes on the water conditioner valve inlet or outlet, and fully into the channel on the single bypass valve. Make sure that the tabs are fully seated.

# Installation Instructions

## ⚠ WARNING



### Electrical Shock Hazard

Prior to installation on metallic plumbing, securely install two grounding clamps and a #4 copper wire per installation instructions.

Failure to follow these instructions can result in death or electrical shock.

## GROUNDING INFORMATION (for Installations on Metal Pipe)

The house main incoming water pipe is often used to ground electrical outlets in the home. Grounding protects you from electrical shock. Installing the water conditioner with a plastic bypass valve will break this ground. Before beginning installation, purchase and securely install two grounding clamps and a #4 copper wire across the location where the conditioner will be, tightly clamping it at both ends, as shown in Figure 13.

**NOTE:** Check local plumbing and electrical codes for proper installation of the ground wire. The installation must conform to them. In Massachusetts, plumbing codes of Massachusetts shall be conformed to. Consult with your licensed plumber.

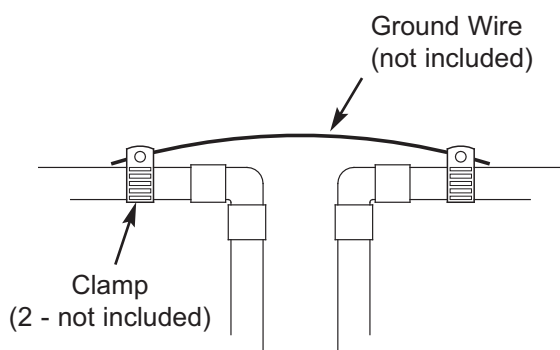

FIG. 13

## COMPLETE INLET AND OUTLET PLUMBING

Measure, cut, and loosely assemble pipe and fittings from the main water pipe to the inlet and outlet ports of the water conditioner valve. Be sure to keep fittings fully together, and pipes squared and straight.

Be sure hard water supply pipe goes to the water conditioner valve inlet side.

**NOTE:** Inlet and outlet are marked on the water conditioner valve. Trace the water flow direction to be sure hard water is to inlet.

**IMPORTANT:** Be sure to fit, align and support all plumbing to prevent putting stress on the water conditioner valve inlet and outlet. Stress from misaligned or unsupported plumbing may cause damage to the valve.

Complete the inlet and outlet plumbing for the type of pipe you will be using.

## INSTALL VALVE DRAIN HOSE

1. Measure, cut to needed length and connect the 3/8" drain line (provided) to the water conditioner valve drain fitting. Use a hose clamp to hold the hose in place.

**NOTE:** Make the valve drain line as short and direct as possible.

**IMPORTANT:** If codes require a rigid drain line see "Valve Drain requirements" section.

2. Route the drain hose or copper tubing to the floor drain. Secure drain hose. This will prevent "whipping" during regenerations. See "Air Gap Requirements" section.

## INSTALL SALT STORAGE TANK OVERFLOW HOSE

1. Measure, cut to needed length and connect the 3/8" drain line (provided) to the salt storage tank overflow elbow and secure in place with a hose clamp.

2. Route the hose to the floor drain, or other suitable drain point no higher than the drain fitting on the salt storage tank (This is a gravity drain). If the tank overfills with water, the excess water flows to the drain point. Cut the drain line to the desired length and route it neatly out of the way.

**IMPORTANT:** For proper operation of the water conditioner, do not connect the water conditioner valve drain tubing to the salt storage tank overflow hose.

---

# Installation Instructions

## ADD WATER AND SALT TO THE SALT STORAGE TANK

### **WARNING**

#### **Excessive Weight Hazard**

**Use two or more people to move and lift salt bags.**

**Failure to do so can result in back or other injury.**

1. Using a container, add about three gallons of clean water into the salt storage tank.
2. Add salt to the storage tank. Use nugget, pellet or coarse solar salts with less than 1% impurities.

## PLUG IN THE POWER SUPPLY

During installation, the water conditioner wiring may be moved or jostled from place. Be sure all leadwire connectors are secure on the back of the electronic board and be sure all wiring is away from the valve gear and motor area, which rotates during regenerations.

1. Plug the power supply into an electrical outlet that is not controlled by a switch.

**NOTE:** The water heater is filled with hard water and, as hot water is used, it will refill with conditioned water. In a few days, the hot water will be fully conditioned. To have fully conditioned hot water immediately, wait until the initial recharge is over. Then, drain the water heater (following instructions for water heater) until water runs cold.

## PROGRAM THE CONTROLLER

1. Install the system's top cover and salt lid.
2. Complete the programming steps on pages 13 & 14.

## RINSE OUT CARBON FINES

Small particles of carbon filtration material are generated during manufacturing and shipping, which will exit the media tank with the first water flow. These carbon "fines" are not harmful, but give the water a gray color and should be rinsed down the drain before any water from the conditioner is directed to the home's faucets or water heater.

**IMPORTANT:** To avoid water or air pressure damage to conditioner inner parts, and to flush pipe chips or other residue from the water pipes, be sure to do the following steps exactly as instructed.

1. Make sure the water conditioner's valve drain hose is hooked up and the open end directed to a floor drain, laundry tub or other suitable type of drain.
2. The system should be connected to electrical power.
3. Place bypass valve(s) in "bypass" position (see Figures 6 & 7). On a single valve, slide the stem inward to bypass. On a 3-valve bypass, close the inlet and outlet valves and open the bypass valve.
4. Fully open the house main water pipe shutoff valve.
5. Initiate a regeneration by pressing and holding for 3 seconds the RECHARGE button (see Figure 15 on page 13). The valve motor will start running and the valve will advance to the "Fill" position.
6. After you hear the valve motor stop running (valve in "Fill" position), press, but do not hold, the RECHARGE button. The valve will advance to the "Brine" position.
7. After you hear the valve motor stop running (valve in "Brine" position), press, but do not hold, the RECHARGE button. The valve will advance to the "Backwash" position.
8. Once the unit is in backwash, place bypass valve(s) in SERVICE, EXACTLY as follows:
  - a. Single Bypass Valve: Slowly, slide pull the valve stem outward toward service, pausing several times to allow the system to pressurize gradually.
  - b. 3-Valve Bypass: Fully close the bypass valve and open the outlet valve. Slowly open the inlet valve, pausing several times to allow the system to pressurize gradually.
9. Let the water conditioner complete the backwash and fast rinse cycles (takes about 20 minutes). When the regeneration ends, the conditioner's valve returns to the service position.

# Installation Instructions

## SANITIZE THE WATER CONDITIONER / SANITIZE AFTER SERVICE

1. Slide open the salt lid, remove the brinewell cover and pour about 90 ml (6 tablespoons) of household bleach into the conditioner brinewell. Replace the brinewell cover.
2. Make sure the bypass valve(s) is in the "service" (open) position.
- 3 **Start a recharge:** Press the RECHARGE button and hold for 3 seconds, until "Recharge Now" begins to flash in the display. This recharge draws the sanitizing bleach into and through the water conditioner. Any air remaining in the unit is purged to the drain.
4. After the recharge has completed, fully open a cold water faucet, downstream from the conditioner, and allow 190 liters of water to pass through the system. This should take at least 20 minutes. Close the faucet.

## TEST FOR LEAKS

To prevent air pressure in the water conditioner and plumbing system, complete the following steps in order:

1. Fully open two or more softened cold water faucets close to the water conditioner, located downstream from the water conditioner.
2. Place the bypass valve (single or 3 valve) into the "bypass" position. See Figures 6 & 7 on Page 7.
3. Slowly open the main water supply valve. Run water until there is a steady flow from the opened faucets, with no air bubbles.
4. Place bypass valve(s) in "service" or soft water position as follows:
  - Single bypass valve: Slowly move the valve stem toward "service," pausing several times to allow the water conditioner to fill with water.
  - 3 valve bypass: Fully close the bypass valve and open the outlet valve. Slowly open the inlet valve, pausing several times to allow the water conditioner to fill with water.
5. After about three minutes, open a hot water faucet until there is a steady flow and there are no air bubbles, then close this faucet.
6. Close all cold water faucets and check for leaks at the plumbing connections that you made.
7. Check for leaks around clips at conditioner's inlet and outlet. If a leak occurs at a clip, depressurize the plumbing (turn off the water supply and open faucets) before removing clip. When removing clips at the conditioner's inlet or outlet, push the single bypass valve body toward the conditioner (See Figure 14). Improper removal may damage clips. Do not reinstall damaged clips.

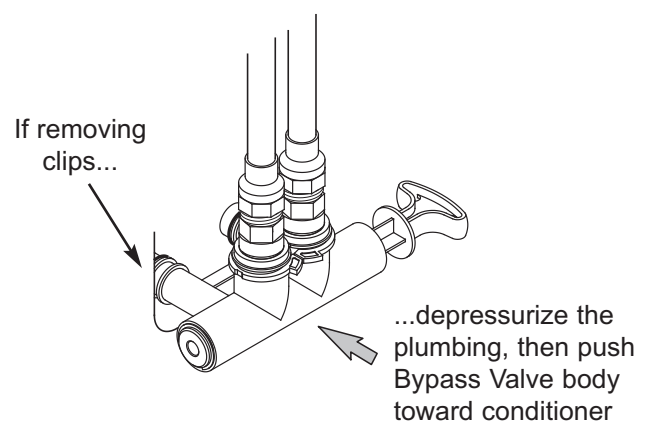

FIG. 14

# Programming the Water Conditioner

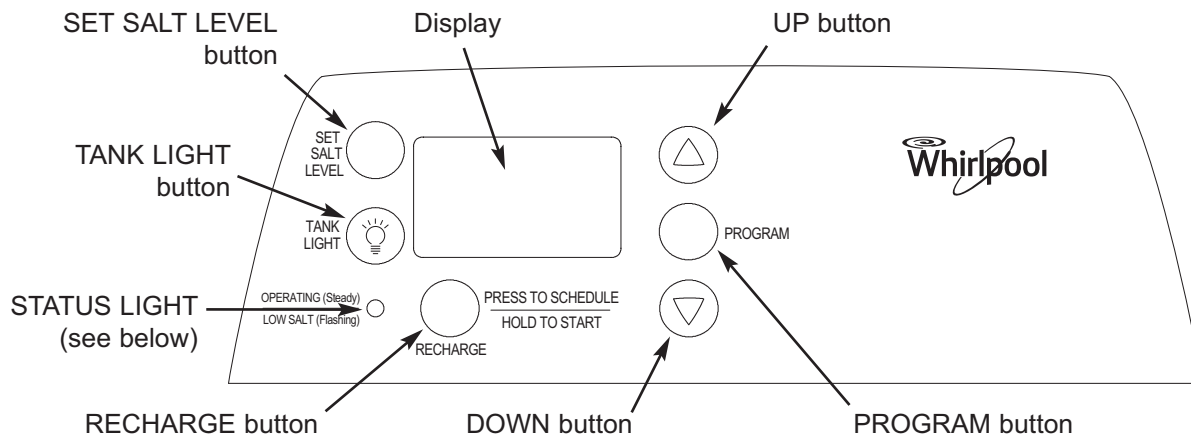

FIG. 15

## STATUS LIGHT

When the water conditioner is connected to electrical power, the status light on the control panel will operate as follows:

- **Light flashing slowly, along with the salt level indicators in the display** - The salt monitor system indicates a low salt level and needs to be set. See "Set Salt Level" on Page 15.
- **Light flashing slowly, along with the words "SCHEDULED CLEAN" in the display** - Four months have elapsed on the system's timer since start up or the last reset. This is a reminder to use Whirlpool® WHE-WSC Water Softener Cleanser three times a year. To reset the timer, press any button on the control panel and the flashing words will disappear. The status light will stop flashing, unless the system is also low on salt (see above).
- **Light flashing rapidly, with "CURRENT TIME" shown in the display and the clock flashing slowly** - The present time needs to be set, either during initial start up or after a long power outage. See "Set Time of Day", at right.
- **Light flashing rapidly, with "Err" shown in the display** - The electronic self-diagnostics have detected a problem. See "Troubleshooting" on Page 20.
- **Light on steady (not flashing)** - The system has power applied and does not require any attention.

## PROGRAM THE CONDITIONER

When the power supply is plugged into the electrical outlet, the model code (LLFC) and a test number (example: J38), are briefly shown in the display. Then the words "CURRENT TIME" appear and 12:00 PM begins to flash.

## SET TIME OF DAY

If the words "CURRENT TIME" do not show in the display, press the PROGRAM button until they do.

1. Press the  $\triangle$  UP or  $\nabla$  DOWN buttons to set the present time. Up moves the display ahead; down sets the time back. Be sure AM or PM is correct.

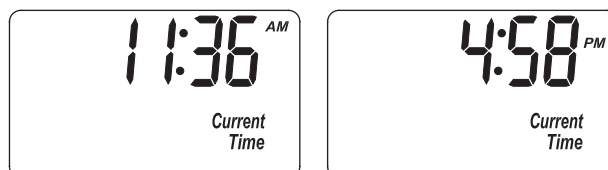

FIG. 16

**NOTE:** Press buttons and quickly release to slowly advance the display. Hold the buttons down for fast advance.

continued on next page

Questions? Call Toll Free 1-866-986-3223 or visit [whirlpoolwatersolutions.com](http://whirlpoolwatersolutions.com)

When you call, please be prepared to provide the model and serial number, found on the rating decal, typically located on the rim below the salt lid hinges.

# Programming the Water Conditioner

## SET WATER HARDNESS NUMBER

1. Press the PROGRAM button once again to display a flashing “25” and the word “HARDNESS”.



FIG. 17

2. Press the  $\triangle$  UP or  $\nabla$  DOWN buttons to set your water's hardness number.

**NOTE:** If your water supply contains iron, compensate for it by adding to the water hardness number. For example, assume your water is 20 gpg hard and contains 2 ppm iron. Add 5 to the hardness number for each 1 ppm of iron. In this example, you would use 30 for your hardness number.

$$\begin{array}{r} 20 \text{ gpg hardness} \\ 2 \text{ ppm iron} \times 5 = 10 \quad +10 \\ \text{(times)} \quad \quad \quad 30 \text{ HARDNESS NUMBER} \end{array}$$

## SET RECHARGE (REGENERATION) TIME

1. Press the PROGRAM button once again to display a flashing “2:00AM” and the words “RECHARGE TIME”. This is a good time for the recharge to start in most households, because water is not in use.



FIG. 18

2. If you want to change the recharge start time, press the  $\triangle$  UP or  $\nabla$  DOWN buttons until the desired time shows. Be sure AM or PM is correct.

## SET SALT TYPE

1. Press the PROGRAM button once again to display a flashing “nACL”.

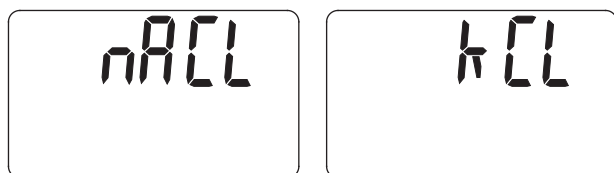

FIG. 19

Salt Type allows you to choose between sodium chloride (NaCl), which is regular softener salt, or potassium chloride (KCl), which is an alternative to sodium chloride. KCl (potassium chloride) may be used if the user of the water conditioner is on a sodium restricted diet and is concerned about the amount of sodium in the water supply.

KCl should be used in accordance with the following steps to help give you years of maintenance free service.

Place only one bag at a time of KCl into your conditioner (the salt storage tank should contain no more than 60 pounds of KCl at any one time).

**NOTE:** A conditioner using KCl should not be located in areas with high temperature changes or high humidity (KCl may harden in these environments and make the conditioner inoperable).

2. Check the brine tank and brinewell (black tube in salt storage tank) monthly. If hardening is present, pour small amounts of warm water on hardened areas until they loosen.
3. Be sure to set the correct salt type, depending on which type of salt is used (NaCl or KCl). Use the  $\triangle$  UP or  $\nabla$  DOWN buttons to toggle between NaCl and KCl, then press the PROGRAM button to enter the selection.
4. Press the PROGRAM button once again to return to normal operating display.

## START A RECHARGE

1. Press the RECHARGE button and hold for three seconds, until “RECHARGE” begins to flash in the display, starting a recharge. This recharge draws the sanitizing bleach into and through the water conditioner. Any air remaining in the water conditioner is purged to the drain. During this time, periodically check for leaks.

**NOTE:** As with all other water system applications, leaks may occur. Leaks may not be immediately apparent. Recheck for leaks 24 hours after first recharge cycle is complete.

# Customizing Features / Options

## RECHARGE

The RECHARGE button is used to initiate an immediate recharge.

1. Press and hold the RECHARGE button until the words "RECHARGE", "SERVICE" and "FILL" flash in the display.

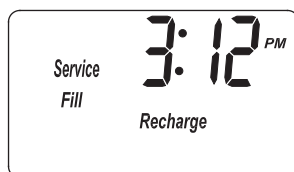

FIG. 20

RECHARGE initiated

The conditioner enters the fill cycle of regeneration right away. "RECHARGE" will flash during the regeneration. When completed, full water conditioning capacity is restored. While water conditioner is running a recharge, the time remaining until the recharge is completed will show in the display during all cycles except for the Fill cycle.

**NOTE:** Avoid using hot water while the conditioner is regenerating, because the water heater will refill with bypass hard water.

## RECHARGE SCHEDULED

If you do not want to start an immediate recharge, but would like to schedule an extra recharge at the next preset recharge time, do the following:

1. Press and release (do not hold) the RECHARGE button.



FIG. 21

RECHARGE scheduled

The words "RECHARGE SCHEDULED" flash in the display, and the conditioner will recharge at the next recharge time. The word "RECHARGE" will flash during the regeneration. When completed, full water conditioning capacity is restored.

## SET SALT LEVEL

The water conditioner has a salt monitor indicator light to remind you to add salt to the storage tank.

**NOTE:** You must set salt level each time salt is added to the water conditioner.

To set this monitor system:

1. Lift the salt lid and level the salt in the storage tank.
2. The salt level scale, on the brinewell inside the tank, has numbers from 0 to 8. Observe the highest number the leveled salt is at, or closest to.
3. Press the SET SALT LEVEL button until black ovals correspond to the salt level number (See Figure 22). At level 2 or below, the "Check Salt Level" LED indicator will flash.

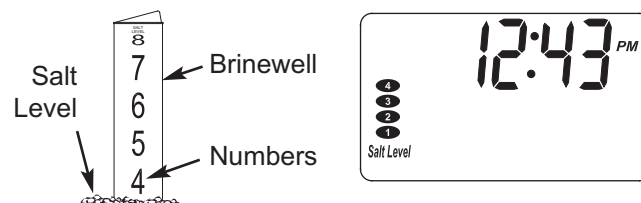

FIG. 22

If you want to turn the salt monitor off, press the SET SALT LEVEL button until "SALT LEVEL OFF" shows in the display (See Figure 23).

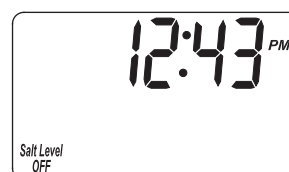

FIG. 23

## TANK LIGHT

The water conditioner is equipped with a tank light for viewing the salt level in the brine tank. Push the tank light button on the electronic control once, and the tank light will turn on. Pushing the tank light button again will turn the light off. The tank light will automatically turn off after a period of 15 minutes if the tank light button is not used to turn it off.

# Customizing Features / Options

## SALT EFFICIENCY

When this feature is ON, the water conditioner will operate at salt efficiencies of 4000 grains of hardness per pound of salt or higher (May recharge more often using smaller salt dosage and less water). The conditioner is shipped with this feature set OFF.

1. Press and hold the PROGRAM button until the screen in Figure 24 is displayed. Once in this display, press the PROGRAM button once and one of the two displays in Figure 25 is shown.



FIG. 24

2. Press the  $\Delta$  UP or  $\nabla$  DOWN buttons to set ON or OFF. When set to ON, the efficiency icon will be displayed in the lower left hand corner of the normal run display.

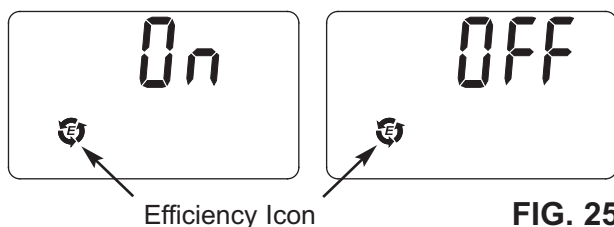

Efficiency Icon

FIG. 25

3. Press the PROGRAM button five times to return to the normal run display.

In the state of California: You must turn the Salt Efficiency Feature ON. This may initiate more frequent recharges. However, it will operate at 4,000 grains per pound of salt or higher.

## CLEAN / CLEAR WATER IRON REDUCTION

This feature is beneficial on water supplies containing ferrous (clear water) iron. The default setting is OFF. When this feature is set to ON, an additional back-wash and fast rinse cycle will occur first, preceding the normal regeneration sequence. This provides extra cleaning of the resin bed before it is regenerated with the salt brine. To conserve water set this feature OFF if your water supply does not contain iron or sediments.

1. Press and hold the PROGRAM button until the screen in Figure 24 is displayed. Once in this display, press the PROGRAM button twice and one of the two displays in Figure 26 is shown.

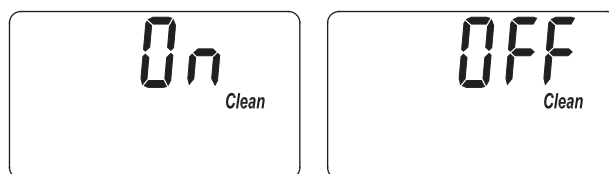

FIG. 26

2. Press the  $\Delta$  UP or  $\nabla$  DOWN buttons to set ON or OFF.
3. Press the PROGRAM button four times to return to the normal run display.

## CLEAN FEATURE MINUTES

The Clean / Clear Water Iron Reduction feature (described above) may be adjusted, from 1 to 15 minutes in length. To change this cycle time, use the UP button to increase the time, or the DOWN button to shorten the time. The default value for this feature is 2 minutes.

1. Press and hold the PROGRAM button until the screen in Figure 24 is displayed. Once in this display, press the PROGRAM button three times and the display in Figure 27 is shown.



FIG. 27

2. Press the  $\Delta$  UP or  $\nabla$  DOWN buttons to set the number of minutes.
3. Press the PROGRAM button three times to return to the normal run display.



# Customizing Features / Options

## CLEANSING FEATURE

The cleansing feature keeps larger particles of sediment from entering the home's plumbing system. As water passes through the softener, the larger sediment particles are collected in the integrated basket and then rinsed to the drain before each regeneration. The cleansing feature provides added protection for water using appliances by reducing the chance of larger particles entering the various products valves and screens. The "Clean Feature" may be turned ON to provide an extra backwash that will help keep the cleansing screen clean. The default is OFF.

**IMPORTANT:** The cleansing feature is not intended to replace pretreatment filtration. For problem water applications, additional sediment filtration is recommended.

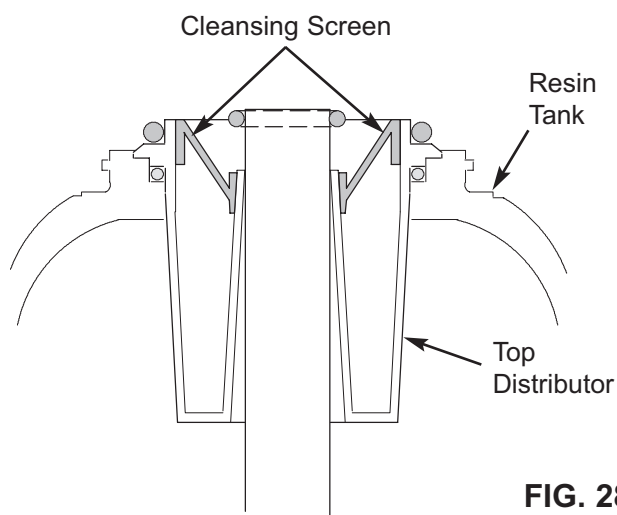

FIG. 28

## MAXIMUM DAYS BETWEEN REGENERATIONS

The water conditioner automatically controls regeneration frequency. This provides the greatest operating efficiency and, under most conditions, this feature should be left in this automatic mode (- - - -). However, you may modify this feature if you want to force a regeneration every set number of days. For example, if your water supply contains clear water iron, you may want the conditioner to regenerate every few days to keep the resin bed clean. The maximum days between recharges may be set from 1 to 15 days, as follows:

**NOTE:** The conditioner will recharge on its own if needed, even if it is before the set number of days.

1. Press and hold the PROGRAM button until the screen in Figure 29 is displayed. Once in this display, press the PROGRAM button four times and the display in Figure 30 is shown.

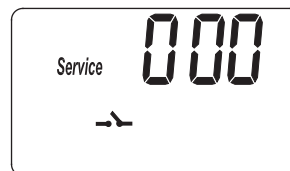

FIG. 29

2. Press the  $\Delta$  UP or  $\nabla$  DOWN buttons to set the number of days.

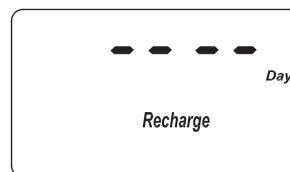

FIG. 30

3. Press the PROGRAM button two times to return to the normal time of day screen.

## 12 OR 24 HOUR CLOCK

All time displays are shown in standard clock time (AM and PM) at the 12 hour default setting. If 24 hour clock displays are desired, follow steps below:

1. Press and hold the PROGRAM button until the screen in Figure 29 is displayed. Once in this display, press the PROGRAM button five times and one of the two displays in Figure 31 is shown.

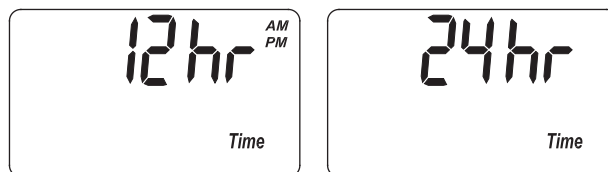

FIG. 31

2. Press the  $\Delta$  UP or  $\nabla$  DOWN buttons to set the time format.
3. Press the PROGRAM button once again, to return to the normal time of day screen.

---

# Customizing Features / Options

## WATER FLOW INDICATOR

Whenever the conditioner has water flowing from the outlet port, the display will show water droplets scrolling down the right hand side of the screen (See Figure 32). The faster the water flow, the faster the droplets will flash.



FIG. 32

Droplets indicate water flow through conditioner

## POWER OUTAGE MEMORY

If electrical power to the water conditioner is lost, "memory" built into the timer circuitry will keep all settings for several hours. While the power is out, the display is blank and the water conditioner will not regenerate. When electrical power is restored, the following will occur:

Reset the present time only if the display is flashing. The HARDNESS and RECHARGE TIME never require resetting unless a change is desired. Even if the clock is incorrect after a long power outage, the conditioner operates as it should to keep your water soft. However, regenerations may occur at the wrong time of day until you reset the clock to the correct time of day.

**NOTE:** If the water conditioner was regenerating when power was lost, it will now finish the cycle.

---

# Routine Maintenance

## WATER SOFTENER CLEANSER

The manufacturer recommends that you use Whirlpool® WHE-WSC Water Softener Cleanser, as directed, every four months.

Lift the brinewell cover and pour in the entire 16 oz. bottle of Whirlpool® Water Softener Cleanser. Press the RECHARGE button and hold for three seconds,

until "RECHARGE" begins to flash in the display. This manual recharge will take about two hours. If taste, odor, or discoloration are detected in the water, manually recharge the conditioner again, then run a cold water faucet immediately downstream of the conditioner until water tastes, smells and appears normal.

# Routine Maintenance

## ADDING SALT

Lift the salt lid and check the salt storage level frequently. If the water conditioner uses all the salt before you refill it, you will experience hard water. Until you have established a refilling routine, check the salt every two or three weeks. Always add if less than 1/4 full. Be sure the brinewell cover is on.

**NOTE:** If using potassium chloride (KCl), do not fill above level 4 on the brinewell scale.

**NOTE:** In humid areas, it is best to keep the salt storage level lower, and to refill more often to avoid salt "bridging".

Recommended Salt: Nugget, pellet or coarse solar salts with less than 1% impurities.

Salt Not Recommended: Rock salt, high in impurities, block, granulated, table, ice melting, ice cream making salts, etc.

## BREAKING A SALT BRIDGE

Sometimes, a hard crust or salt "bridge" forms in the brine tank. It is usually caused by high humidity or the wrong kind of salt. When the salt "bridges," an empty space forms between the water and the salt. Then, salt will not dissolve in the water to make brine. Without brine, the resin bed is not recharged and hard water will result.

If the storage tank is full of salt, it is difficult to tell if you have a salt bridge. A bridge may be underneath loose salt. Take a broom handle, or like tool, and hold it next to the water conditioner. Measure the distance from the floor to the rim of the water conditioner. Then, gently push the broom handle straight down into the salt. If a hard object is felt before the pencil mark is even with the top, it is most likely a salt bridge. Gently push into the bridge in several places to break it. Do not use any sharp or pointed objects as you may puncture the brine tank. Do not try to break the salt bridge by pounding on the outside of the salt tank. You may damage the tank.

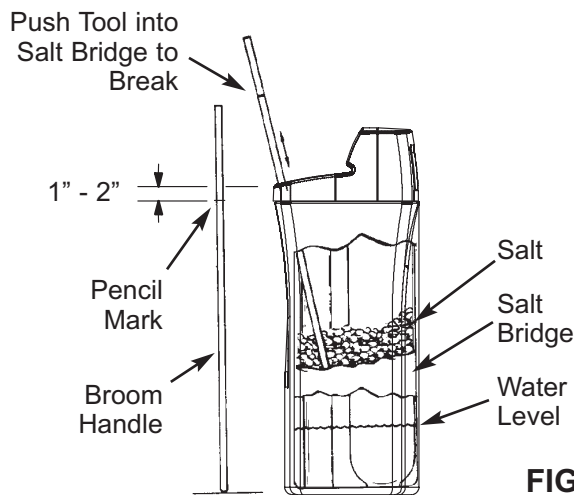
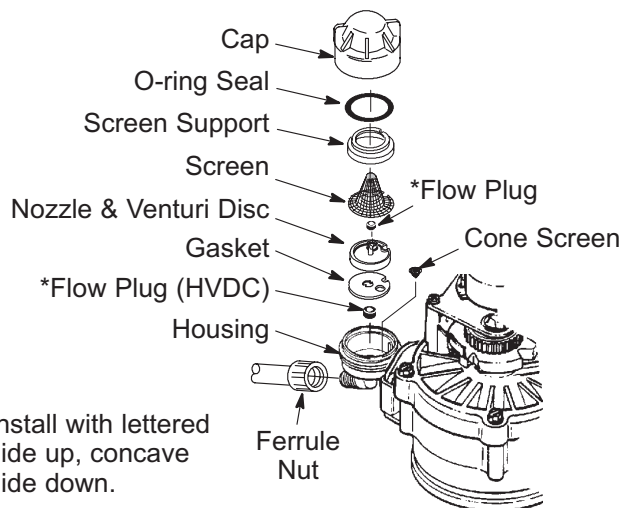

FIG. 33

## CLEANING THE NOZZLE & VENTURI

A clean nozzle & venturi (See Figure 34) is a necessity for the water conditioner to work properly. This small component creates the suction to move brine from the brine tank, into the resin tank. If it should become plugged with sand, silt, dirt, etc., the water conditioner will not work, and hard water will result.



\*Install with lettered side up, concave side down.

**IMPORTANT:** Be sure small hole in the gasket is centered directly over the small hole in the nozzle & venturi housing. Be sure the numbers are facing up

FIG. 34

To get access to the nozzle & venturi, remove the water conditioner's top cover. Put the bypass valve(s) into the bypass position. Be sure the water conditioner is in soft water (service) cycle (no water pressure at nozzle & venturi). Then, holding the nozzle & venturi housing with one hand, unscrew the cap. Do not lose the o-ring seal. Lift out the screen support and screen. Then, remove the nozzle & venturi disc, gasket and flow plug(s). Wash the parts in warm, soapy water and rinse in fresh water. Be sure to clean both the top and bottom of the nozzle & venturi disc. If needed, use a small brush to remove iron or dirt. Do not scratch, misshape, etc., surfaces of the nozzle & venturi.

Gently replace all parts in the correct order. Lubricate the o-ring seal with silicone grease and locate in place. Install and tighten the cap by hand, while supporting the housing. Overtightening may break the cap or housing. Put the bypass valve(s) into service (soft water) position.

Recharge the conditioner to reduce water level in the tank. This will also assure that the conditioner is completely recharged and ready to provide softened water again. Check the water level in the tank by looking down the brinewell. If the water level does not drop after a recharge, the problem has not been resolved. Call 1-866-986-3223.

# Troubleshooting

## AUTOMATIC ELECTRONIC DIAGNOSTICS

This water conditioner has a self-diagnostic function for the electrical system (except input power and/or water meter). The water conditioner monitors electronic components and circuits for correct operation. If a malfunction occurs, an error code appears in the display.

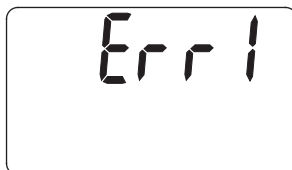

FIG. 35

While an error code appears in the display, all buttons are inoperable except the PROGRAM button. PROGRAM remains operational so the service person can perform the Manual Advance Diagnostics, see below, to further isolate the problem.

### Procedure for removing error code from display:

1. Unplug power supply from electrical outlet.
2. Correct problem.
3. Plug power supply back in.
4. Wait 8 minutes. The error code will return if the problem was not corrected.

## MANUAL ADVANCE DIAGNOSTICS

Use the following procedures to advance the water conditioner through the regeneration cycles to check operation.

Lift off the salt lid, remove the top cover by unlocking the tabs in the back and rocking forward, to observe cam and switch operation during valve rotation.

1. Press and hold PROGRAM for 3 seconds until "000" shows in the display, then release.
2. The 3 digits indicate water meter operation as follows:
  - 000 (steady) = Soft water not in use, and no flow through the meter.Open a nearby soft water faucet.
- 000 to 140 (continual) = Repeats for each gallon of water passing through the meter.

3. Symbols in the display indicate POSITION switch operation (See Figure 36).

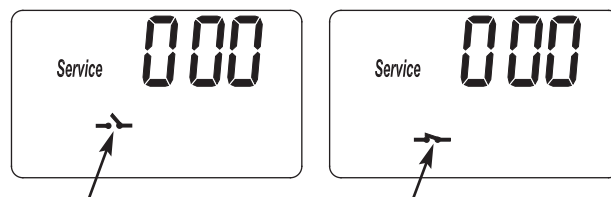

- Switch is open (Cam not rotating)      Switch is closed (Cam rotating)

FIG. 36

4. Use the RECHARGE button to manually advance the valve into each cycle and check correct switch operation.

**NOTE:** Be sure water is in contact with the salt, and not separated by a salt bridge (See "Breaking A Salt Bridge" section).

5. While in this diagnostic screen, the following information is available and may be beneficial for various reasons. This information is retained by the computer from the first time electrical power is applied to the electronic controller.
  - a. Press the  $\triangle$  UP button to display the number of days this electronic control has had electrical power applied.
  - b. Press the  $\nabla$  DOWN button to display the number of regenerations initiated by this electronic control since the code number was entered.
6. Press and hold the PROGRAM button until the model code (LLFC) shows in the display. This code identifies the conditioner model. If an incorrect model code is displayed, the conditioner will operate on incorrect configuration data.

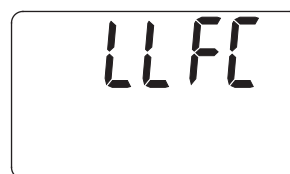

FIG. 37

7. To change the code number, press the  $\triangle$  UP or  $\nabla$  DOWN button until the correct code shows.
8. To return to the present time display, press the PROGRAM button.

# Troubleshooting

## RESETTING TO FACTORY DEFAULTS

To reset the electronic controller to its factory default for all settings (time, hardness, etc.):

1. Press the PROGRAM button and hold it until the display changes twice to show the flashing model code.
2. Press the  $\triangle$  UP button (a few times, if necessary) to display a flashing "SoS".

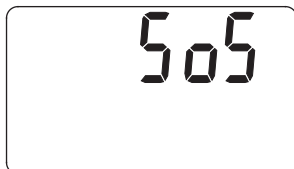

FIG. 38

3. Press the PROGRAM button, and the electronic controller will restart.
4. Set the present time, hardness, etc., as described on pages 13 & 14.

## MANUAL ADVANCE REGENERATION CHECK

This check verifies proper operation of the valve motor, brine tank fill, brine draw, regeneration flow rates, and other controller functions. Always make the initial checks, and the manual initiated diagnostics.

**NOTE:** The electronic control display must show a steady time (not flashing). If an error code shows, first press the PROGRAM button to enter the diagnostic display.

1. Press the RECHARGE button and hold in for 3 seconds. RECHARGE begins to flash as the conditioner's valve advances from the service to fill position. Remove the brinewell cover and, using a flashlight, observe fill water entering the tank.

If water does not enter the tank, look for an obstructed nozzle, venturi, fill flow plug, brine tubing, or brine valve riser pipe.

2. After observing fill, press the RECHARGE button to move the conditioner's valve into the brine position. A slow flow of water to the drain will begin. Verify brine draw from the brine tank by shining a flashlight into the brinewell and observing a noticeable drop in the liquid level. This may take 15 to 20 minutes.

**NOTE:** Be sure water is in contact with the salt, and not separated by a salt bridge (See "Breaking A Salt Bridge" section).

If the water conditioner does not draw brine, check for (most likely to least likely):

- Dirty or plugged nozzle and venturi, see "Cleaning the Nozzle and Venturi" section.
- Nozzle and venturi not seated on the gasket, or gasket deformed.
- Valve seals leaking (See Troubleshooting).
- Restriction in valve drain, causing a back-pressure (bends, kinks, elevated too high, etc.). See "Install Valve Drain Hose" section.
- Obstruction in brine valve or brine tubing.

**NOTE:** If water system pressure is low, a too-long or elevated drain hose may cause back pressure, stopping brine draw. Avoid drain hose runs longer than 30 feet. Avoid elevating the hose more than 8 feet above the floor.

3. Press the RECHARGE button to move the conditioner's valve into the backwash position. Look for a fast flow of water from the drain hose. Check that the drain can adequately handle the flow and volume.

An obstructed flow indicates a plugged top distributor, backwash flow plug, or drain hose.

4. Press the RECHARGE button to move the conditioner's valve into the fast rinse position. Again look for a fast drain flow. Allow the conditioner to rinse for a few minutes to flush out any brine that may remain in the resin tank from the brining cycle test.

5. To return the conditioner's valve to the service position, press the RECHARGE button.

**Need help troubleshooting? Call Toll Free 1-866-986-3223 or visit [whirlpoolwatersolutions.com](http://whirlpoolwatersolutions.com)**

When you call, please be prepared to provide the model and serial number, found on the rating decal, typically located on the rim below the salt lid hinges.

# Conditioner Exploded View

**Valve Assembly**  
See Pages 24 & 25  
for parts

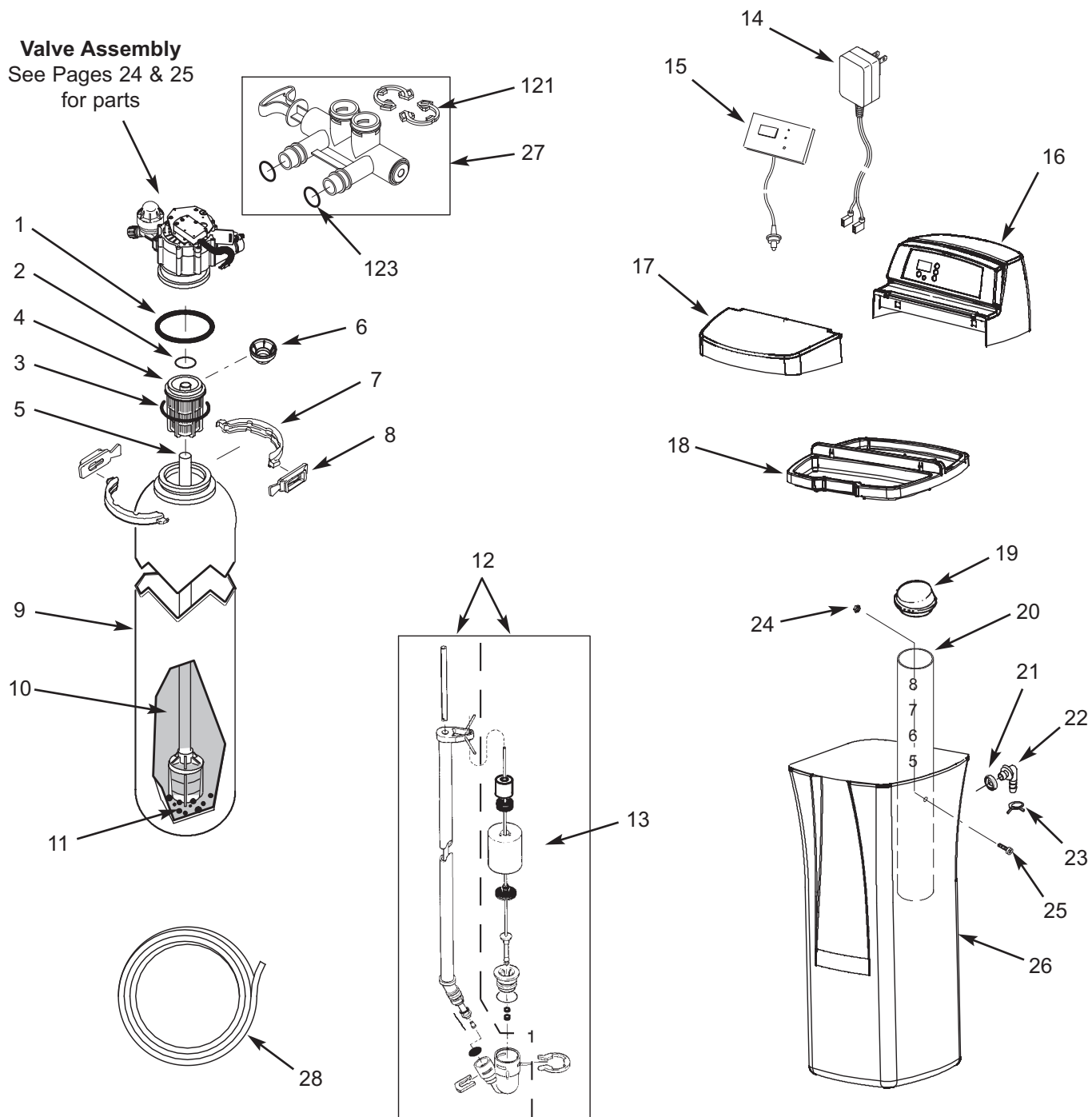

# Conditioner Parts List

Key No.	Part No.	Description
–	7112963	Distributor O-Ring Kit (includes Key Nos. 1-3)
1	↑	O-Ring, 2-7/8" x 3-1/4"
2	↑	O-Ring, 13/16" x 1-1/16"
3	↑	O-Ring, 2-3/4" x 3"
4	7077870	Top Distributor
5	7105047	Repl. Bottom Distributor
6	7265025	Filter Screen
–	7331177	Tank Neck Clamp Kit (includes 2 ea. of Key Nos. 7 & 8)
7	↑	Clamp Section (2 req.)
8	↑	Retainer Clip (2 req.)
9	7247996	Repl. Resin Tank, 10" x 40"
10	0502272	Resin, 1 cu. ft.
	7301619	Activated Carbon
11	7124415	Gravel
12	7310202	Repl. Brine Valve Assembly
13	7327568	Float, Stem & Guide Assembly
14	7351054	Power Supply, 24V DC
15	7335163	Repl. Electronic Control Board (PWA)
16	7346588	Top Cover & Faceplate Assembly, (order decal below)
■	7346067	Faceplate Decal

Key No.	Part No.	Description
17	7332131	Salt Lid (order decal below)
■	7336622	Instruction Decal
18	7305299	Rim
19	7335901	Cover, Brinewell
20	7137824	Brinewell Assembly (including salt level decal)
–	7331258	Overflow Hose Adaptor Kit (includes Key Nos. 21-23)
21	↑	Grommet
22	↑	Adaptor Elbow
23	↑	Hose Clamp
–	7331664	Brinewell Mounting Hardware Kit (includes Key Nos. 24 & 25)
24	↑	Wing Nut, 1/4-20
25	↑	Screw, 1/4-20 x 1-1/2"
26	7305249	Repl. Brine Tank
27	7214383	Bypass Valve Assembly, 1", including 2 ea. Clips & O-Rings (See Key Nos. 121 & 123)
28	7139999	Drain Hose, 20 ft.
■	7346075	Owner's Manual

■ Not illustrated.

To order repair parts call toll free 1-866-986-3223.

Manufactured and warranted by  
Ecodyne Water Systems  
1890 Woodlane Drive  
Woodbury, MN 55125

**Questions? Call Toll Free 1-866-986-3223** or visit [whirlpoolwatersolutions.com](http://whirlpoolwatersolutions.com)

When you call, please be prepared to provide the model and serial number, found on the rating decal, typically located on the rim below the salt lid hinges.

# Valve Exploded View

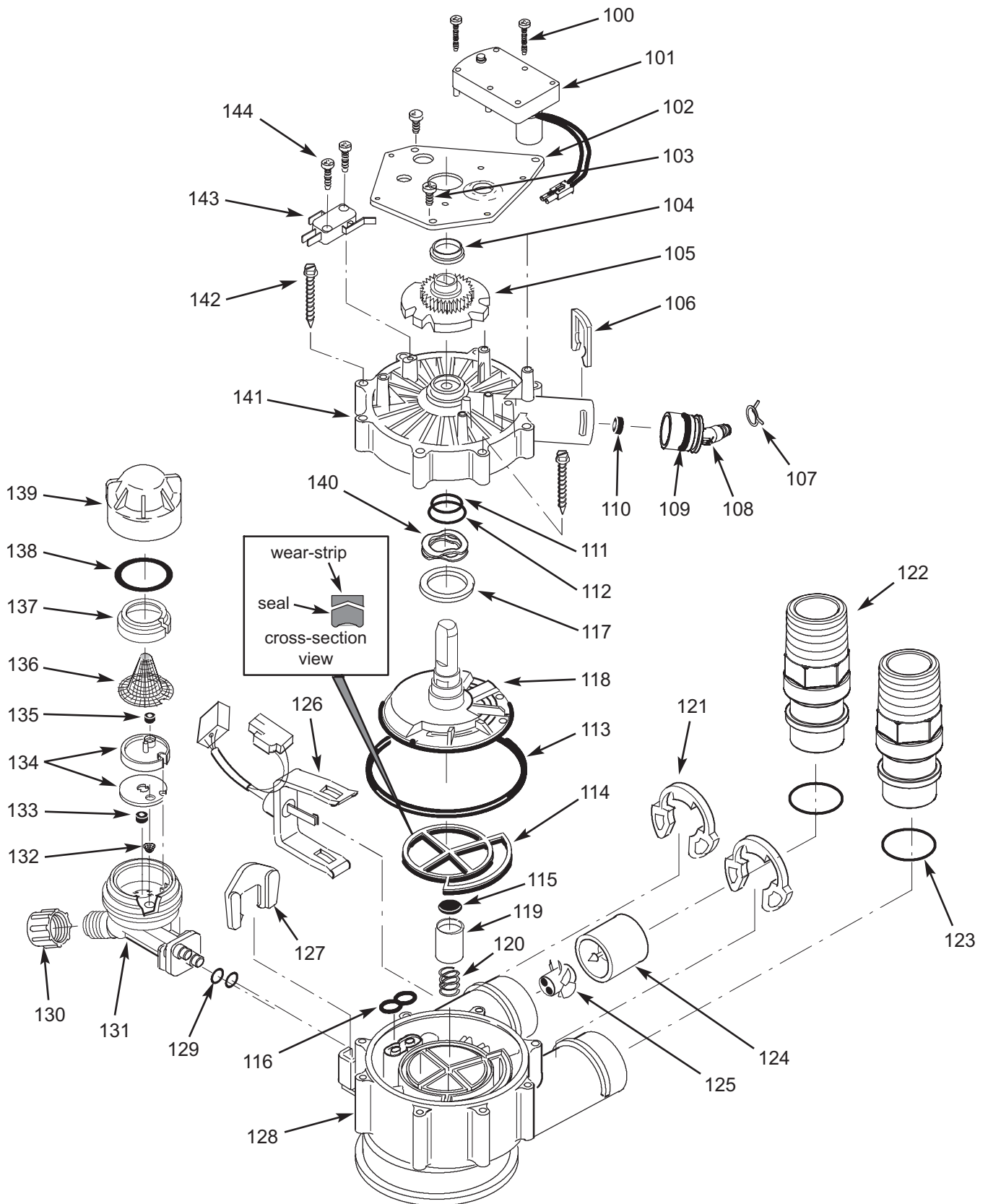



# Valve Parts List

Key No.	Part No.	Description
100	7224087	Screw, #8-32 x 1" (2 req.)
101	7286039	Motor (incl. 2 ea. of Key No. 100)
102	7231393	Motor Plate
103	0900857	Screw, #6-20 x 3/8" (3 req.)
104	7171250	Bearing
105	7283489	Cam & Gear
-	7331169	Drain Hose Adaptor Kit (includes Key Nos. 106-110)
106	↑	Clip, Drain
107	↑	Hose Clamp
108	↑	Drain Hose Adaptor
109	↑	O-Ring, 15/16" x 1-3/16"
110	↑	Flow Plug, 2.0 gpm
-	7185487	Seal Kit (includes Key Nos. 111-116)
111	↑	O-Ring, 5/8" x 13/16"
112	↑	O-Ring, 1-1/8" x 1-1/2"
113	↑	O-Ring, 4-1/2" x 4-7/8"
114	↑	Rotor Seal
115	↑	Seal
116	↑	Seal, Nozzle & Venturi
117	7174313	Bearing, Wave Washer
118	7185500	Rotor & Disc
-	7342712	Drain Plug Kit, 1" (includes Key Nos. 115, 119 & 120)
119	↑	Plug, Drain Seal
120	↑	Spring
121	7337589	Clip, 1", pack of 4
122	7342704	Installation Adaptor, 1", pack of 2, including 2 ea. Clips & O-Rings (See Key Nos. 121 & 123)

Key No.	Part No.	Description
123	7337597	O-Ring, 1-1/16" x 1-5/16", pack of 4
-	7290931	Turbine & Support Assembly, including 2 O-Rings (See Key No. 123) & 1 ea. of Key Nos. 124 & 125
124	↑	Turbine Support & Shaft
125	↑	Turbine
126	7309811	Wire Harness, Sensor
127	7081201	Retainer, Nozzle & Venturi
128	7171145	Valve Body
129	7342649	O-Ring, 1/4" x 3/8", pack of 2
130	1202600	Nut - Ferrule
-	7257454	Nozzle & Venturi Assembly (incl. Key Nos. 127, 129 & 131-139)
131	7081104	Housing, Nozzle & Venturi
132	7095030	Cone Screen
133	1148800	Flow Plug, .3 gpm
134	7114533	Nozzle & Venturi Gasket Kit
	7204362	Gasket Only
135	7084607	Flow Plug, .15 gpm
136	7146043	Screen
137	7167659	Screen Support
138	7170262	O-Ring, 1-1/8" x 1-3/8"
139	7199729	Cap
140	7175199	Wave Washer
141	7171161	Valve Cover
142	7342681	Screw, #10 x 2-5/8", pack of 8
143	7305150	Switch
144	7140738	Screw, #4-24 x 3/4" (2 req.)
■	3479901	Adaptor Kit, 1" to 1-1/4"

■ Not illustrated.

To order repair parts call toll free 1-866-986-3223.

Manufactured and warranted by  
Ecodyne Water Systems  
1890 Woodlane Drive  
Woodbury, MN 55125

**Questions? Call Toll Free 1-866-986-3223** or visit [whirlpoolwatersolutions.com](http://whirlpoolwatersolutions.com)

When you call, please be prepared to provide the model and serial number, found on the rating decal, typically located on the rim below the salt lid hinges.

## WATER CONDITIONER WARRANTY - MODEL WHESFC

Warrantor: Ecodyne Water Systems, 1890 Woodlane Drive, Woodbury, MN 55125

Warrantor guarantees, to the original owner, that:

### Two Year Full Warranty:

- When installed by a Lowe's Professional Series installer,\* for a period of two (2) years from the date of purchase, all parts will be free from defects in materials and workmanship and will perform their normal functions.
- When installed by a Lowe's Professional Series installer,\* for a period of two (2) years from the date of purchase, labor to repair or replace any part deemed to be defective in materials or workmanship, will be provided at no additional cost.

### Limited Warranties:

- For a period of ten (10) years from the date of purchase, the salt storage tank and fiberglass mineral tank will not rust, corrode, leak, burst, or in any other manner, fail to perform its proper functions.
- For a period of three (3) years from the date of purchase, the electronic control board will be free of defects in materials and workmanship and will perform its normal functions.

If, during such respective period, a part proves to be defective, Warrantor will ship a replacement part, directly to your home, without charge. After the second year, labor necessary to maintain this product is not covered by the product warranty. If you have questions regarding a warranted product, need assistance with installation or troubleshooting, wish to order a part or report a warranty issue, we are just a phone call away. SIMPLY DIAL 1-866-986-3223 for assistance.

### General Provisions

The above warranties are effective provided the water conditioner is operated at water pressures not exceeding 125 psi, and at water temperatures not exceeding 100°F; provided further that the water conditioner is not subject to abuse, misuse, alteration, neglect, freezing, accident or negligence; and provided further that the water conditioner is not damaged as the result of any unusual force of nature such as, but not limited to, flood, hurricane, tornado or earthquake.

Warrantor is excused if failure to perform its warranty obligations is the result of strikes, government regulation, materials shortages, or other circumstances beyond its control.

**THERE ARE NO WARRANTIES ON THE WATER CONDITIONER BEYOND THOSE SPECIFICALLY DESCRIBED ABOVE. ALL IMPLIED WARRANTIES, INCLUDING ANY IMPLIED WARRANTY OF MERCHANTABILITY OR OF FITNESS FOR A PARTICULAR PURPOSE, ARE DISCLAIMED TO THE EXTENT THEY MIGHT EXTEND BEYOND THE ABOVE PERIODS. THE SOLE OBLIGATION OF WARRANTOR UNDER THESE WARRANTIES IS TO REPLACE OR REPAIR THE COMPONENT OR PART WHICH PROVES TO BE DEFECTIVE WITHIN THE SPECIFIED TIME PERIOD, AND WARRANTOR IS NOT LIABLE FOR CONSEQUENTIAL OR INCIDENTAL DAMAGES. NO WARRANTOR DEALER, AGENT, REPRESENTATIVE, OR OTHER PERSON IS AUTHORIZED TO EXTEND OR EXPAND THE WARRANTIES EXPRESSLY DESCRIBED ABOVE.**

Some states do not allow limitations on how long an implied warranty lasts or exclusions or limitations of incidental or consequential damage, so the limitations and exclusions in this warranty may not apply to you. This warranty gives you specific legal rights, and you may have other rights which vary from state to state. This warranty applies to consumer-owned installations only.

\* Warranty period will be one (1) year from the date of purchase if installation is not purchased from Lowe's. Proof of purchase of the softener and installation are required to validate warranty.

®/TM © 2016 Whirlpool. All rights reserved.

Manufactured under license by Ecodyne Water Systems, Woodbury, Minnesota.

Limited warranty provided by manufacturer.